



# AEROBIC SYSTEMS, INC.

2885 Highway 14 East Lake Charles, Louisiana 70607  
(337) 474-2804 phone (337) 477-7904 fax  
[www.hootsystems.com](http://www.hootsystems.com)

## DRIP DISPOSAL DESIGN & INSTALLATION GUIDE

This manual is expressly to convey recommendations to guide in the design and installation of the Hoot Drip Irrigation and Management System. These recommendations are only suggestions and local regulations, if more restrictive, must be followed, regardless of our recommendations. Installers must follow the design of the Professional Engineer who has designed the system for the specific design application.

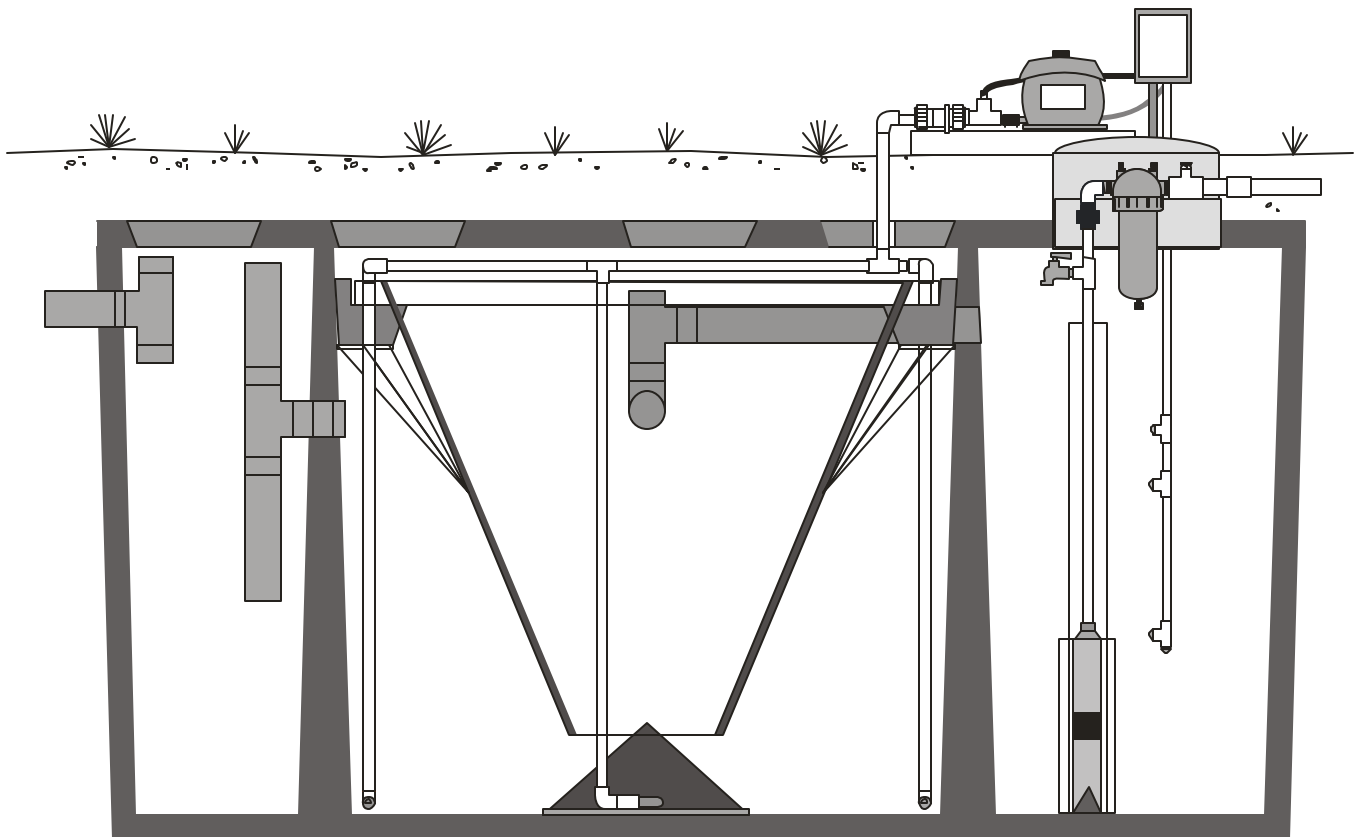

**WARNING! TO PREVENT MALFUNCTION OF YOUR SEWAGE SYSTEM, DO NOT DISCHARGE THE FOLLOWING MATERIALS INTO THE SYSTEM:** Plastic Materials ! Cloth ! Cigarette Stubs ! Large quantities of acids or caustics, soaps or cleaning materials which have a high or low pH factor (Use low suds detergents) ! Throw-away Diapers ! Baby wipes ! Paper Towels ! Kleenex & some toilet tissues which do not decompose readily in water ! Rubber products ! Excess grease or fatty materials (Use garbage disposal sparingly) ! Oily materials, motor oils, grease, kerosene, gasoline, Paints, etc. ! Backwash water from water softeners ! Any other materials which do not disintegrate readily in water ! Gutters ! Pool Filter Discharge ! Hot Tubs/Jacuzzi Water ! SUMP PUMP DISCHARGE

**WARNING!** TO FUNCTION PROPERLY, THE HOOT SYSTEM MUST BE MAINTAINED BY A QUALIFIED PROFESSIONAL AT LEAST EVERY SIX (6) MONTHS FOR THE LIFE OF THE SYSTEM. FAILURE TO MAINTAIN THE HOOT SYSTEM VOIDS THE LIMITED WARRANTY AND MAY CAUSE SERIOUS BODILY INJURY OR ILLNESS TO PEOPLE AND PETS AND MAY CAUSE SERIOUS DAMAGE TO THE HOOT SYSTEM OR OTHER PROPERTY.

**DANGER!** ONLY A QUALIFIED PROFESSIONAL SHOULD ATTEMPT TO REPAIR OR FIX THE HOOT SYSTEM. ATTEMPTED REPAIR BY ANYONE OTHER THAN A QUALIFIED PROFESSIONAL MAY CAUSE SERIOUS BODILY INJURY OR DEATH TO THE HOMEOWNER OR OTHER PERSONS AND MAY CAUSE SERIOUS DAMAGE TO THE HOOT SYSTEM AND OTHER PROPERTY.

**DANGER!** DO NOT DISCONNECT THE POWER TO THE HOOT SYSTEM. DISCONNECTION OF THE POWER FROM THE SYSTEM MAY CAUSE SERIOUS ILLNESS OR DEATH TO THE HOMEOWNER AND OTHER PERSONS AND MAY CAUSE SERIOUS DAMAGE TO THE HOOT SYSTEM AND OTHER PROPERTY.

**WARNING!** IN CASE OF IMMINENT FLOOD, IMMEDIATELY TURN OFF THE ELECTRICAL POWER TO THE HOOT SYSTEM AT THE INDEPENDENT BREAKER LOCATED ON THE HOUSE. FAILURE TO TURN OFF THE ELECTRICAL POWER MAY CAUSE SERIOUS INJURY OR DEATH TO THE HOMEOWNER AND OTHER PERSONS AND MAY CAUSE SERIOUS DAMAGE TO THE HOOT SYSTEM AND OTHER PROPERTY.

**WARNING!** IF THE UNIT FAILS TO FUNCTION PROPERLY, DO NOT USE THE BATHROOM FACILITIES UNTIL QUALIFIED PERSONNEL FIX THE PROBLEM. USE OF THE BATHROOM FACILITIES DURING A SYSTEM FAILURE MAY CAUSE SERIOUS INJURY, ILLNESS, OR DEATH TO PERSONS AND MAY CAUSE SERIOUS DAMAGE TO THE HOOT SYSTEM AND OTHER PROPERTY.

**WARNING!** DO NOT ALLOW CHILDREN TO PLAY ON OR AROUND THE AEROBIC TREATMENT SYSTEM, DISPOSAL SYSTEM, OR OTHER OVER-LAND DISCHARGE AREA. ALLOWING CHILDREN TO PLAY IN THESE AREAS MAY CAUSE SERIOUS BODILY INJURY, ILLNESS, OR DEATH TO THE CHILDREN AND OTHER PERSONS AND MAY CAUSE DAMAGE TO THE HOOT SYSTEM AND OTHER PROPERTY.

**DANGER!** DO NOT OPEN CONTROL PANEL WITHOUT ELECTRICITY DISCONTINUED AND LOCKED OUT ON THE SYSTEM. FAILURE TO DO SO COULD CAUSE SEVERE INJURY OR DEATH



# Drip Design Guide

## I. Introduction to Drip

The purpose of this design guide is to detail the equipment and design considerations necessary for the effective application of Hoot Aerobic Systems utilizing drip irrigation technology to the onsite wastewater field.

Drip Irrigation was originally developed for the agriculture industry as a technique to improve the efficiency of water delivered to plants, especially in environments where water supply is limited. The technique involves delivering only those amounts of water that plants actually use into the root zone, and relying on horizontal as well as vertical movement through the soil to disperse the water. Hoot Aerobic Systems utilizes components supplied by the Netafim Corporation, a world leader in drip applications. Their products, including pressure compensating emitters, filters, valves and other products have become industry standards.

The goal of delivering water in the shallow subsurface and in the root zone of plants enables the wastewater designer to take advantage of evapotranspiration, plant uptake for nutrient removal, and slow dispersal in the soil medium.

With High levels of Pre-Treatment, provided by the Hoot Aerobic System, and physical filtration of the effluent, failed drainfields are a thing of the past. If the system fails, the problem is in the tank, which can be pumped, not a drainfield that needs to be replaced.

Within the last few years, the EPA has recognized that on-site treatment and disposal of wastewater is a permanent alternative rather than a temporary solution for wastewater treatment and disposal when centralized collection systems are not feasible. Increasing public concern about issues related to the effective

It has come to our attention that systems are and reliable treatment and disposal of wastewater on-site has created a climate for change beyond septic tanks and drainfields.

Hoot Aerobic Systems has responded with improved technology for wastewater treatment and regulations have become more explicit and scientifically based. These are key reasons why interest in drip disposal within the on-site industry has rapidly increased.

While the EPA and the Florida Department of Health have identified on-site disposal of wastewater as a satisfactory long-term solution, it is still necessary to prevent human contact with contaminants and pathogens in untreated wastewater. Examples of failures of this requirement are:

- Surfacing of Failing Conventional Septic Systems
- Under treated effluent entering ground water
- Contact of wastewater with surface waters in lakes or streams

As the demand increases for residential development in rural areas and in sub-optimal conditions for onsite wastewater disposal, the significance for alternative technologies increases. The use of a Hoot Aerobic System with drip disposal is the most effective strategy for a wide variety of the most demanding on-site wastewater design parameters.

In addition to simply “getting rid of” wastewater, drip disposal has a number of benefits:

- Water can be re-used for irrigation of lawns, shrubs, or trees;

The disposal area can remain intact, taking advantage of natural or modified landscape strategies;  
Beneficial wastewater nutrients are available for plant uptake;

With proper design, drip irrigation can be applied in almost any climate or soil conditions.

The following design manual provides basic design guidelines for drip system design, installation, maintenance, and operation. However, because such designs are subject to state and local regulatory requirements for on-site wastewater systems, any regulatory specification must be given precedence over the recommendations included herein. If local regulations allow design parameters which exceed the following recommendations, the designer should bear in mind that **the following recommendations are based on actual design experience and analysis of a variety of failed on-site systems.**

Common causes of drip system failure include:

- Overestimation of soil absorption potential
- Underestimation of wastewater load
- Poor system layouts
- Inappropriate dosing schedules.

*Recommendation: use state regulations only when they are more restrictive than this design guide, not less restrictive.*

This can easily be achieved by any properly designed and maintained Hoot Aerobic System.

Effluent leaves the Hoot Treatment system and enters an adequately designed storage tank. The Storage tanks are designed to allow for both a working level and reserve capacity above the high water level alarm.

The drip system is designed to distribute the wastewater uniformly over the drip field and throughout the 24 hour day. The drip control system regulates this flow and can provide for back-flushing, zone shifting, and alarms whenever operational conditions are exceeded.

Since drip tubing requires operating pressure, this design manual is built around our 20 GPM Hoot Effluent Blaster. Pressure is also required to operate filters (automatic or manual back flush), which are necessary to remove organic and inorganic suspended solids. These suspended solids can be a significant problem for drip emitters and can even clog piping over time. Zone layout is necessary to keep pumps small and inexpensive. Yet pump capacity must allow for the achievement of scouring velocity (2 ft. per second) at the return ends of distribution lines and drip tubing during manual or automatic field flush cycles.

Drip tubing is normally installed at a minimum depth of 6", but 10" to 12" depths are recommended to minimize human contact potential. Cold climates may require even deeper burial, based on local conditions. Installation below the soil freeze depth is generally safe, but there are examples of satisfactory installations at relatively shallow depths in cold climates *if* there is a continuous flow of wastewater—even highly treated wastewater. It appears that the warmth of the wastewater achieved by circulation in a residence and by oxidation of the organics prevents freezing in the soil, even when soil moisture would normally freeze.

Most critical to a proper design is matching the soil capacity to absorb water with the demand for disposal of the design flow. In this regard, the designer must take account of water flow over, into, and through the soil; storage of water in the soil column; the loss of water to the air through evaporation; loss through uptake in the roots; and exchange to the air through the leaves of plants (evapotranspiration).

The following design guide shows in more detail how accurate information about daily wastewater flow, along with proper soil analysis and site evaluation, can lead to a properly sized complete, successful, and cost-effective drip system.

## II. Wastewater Flow Determination

A drip disposal system must accommodate the amount of wastewater effluent generated. The following table can be used for estimating the daily wastewater production rate for various activities. Actual water usage data or other methods of calculating wastewater usage rates must be used by the system designer if it is determined that, for whatever reason, these quantities exceed the standard estimates. In any case, estimates used for on-site wastewater treatment designs must be approved by local regulatory authorities. The following table from EPA is widely used for wastewater flow estimation.

TYPE OF FACILITY	USAGE RATE GALLONS/DAY (Without Water Saving Devices)	USAGE RATE GALLONS/DAY (With Water Saving Devices)
Single family dwelling (one or two bedrooms) - less than 1,500 sq. feet.	225	180
Single family dwelling (three bedrooms) - less than 2,500 sq. feet.	300	240
Single family dwelling (four bedrooms) - less than 3,500 sq. feet.	375	300
Single family dwelling (five bedrooms) - less than 4,500 square feet.	450	360
Single family dwelling (six bedrooms) - less than 5,500 square feet.	525	420
Greater than 5,500 square feet, each additional 1,500 square feet or Increment thereof.	75	60
Condominium or Townhouse (one or two bedrooms)	225	180
Condominium or Townhouse (each additional bedroom)	75	60
Mobile home (one or two bedrooms)	225	180
Mobile home (each additional bedroom)	75	60
Country Clubs (per member)	25	20
Apartment houses (per bedroom)	125	100
Boarding schools (per room capacity)	50	40
Day care centers (per child with kitchen)	25	20
Day care centers (per child without kitchen)	15	12
Factories (per person per shift)	15	12
Hospitals (per bed)	200	160
Hotels and motels (per bed)	75	60
Nursing homes (per bed)	100	80
Laundries (self service per machine)	250	200
Lounges (bar and tables per person)	10	8
Movie Theaters (per seat)	5	4
Office buildings (no food or showers per occupant)	5	4
Office buildings (with food service per occupant)	10	4
Parks (with bathhouse per person)	15	12
Parks (without bathhouse per person)	10	12
Restaurants (per seat)	35	28
Restaurants (fast food per seat)	15	28
Schools (with food service & gym per student)	25	20
Schools (without food service)	15	20
Service stations (per vehicle)	10	8
Stores (per washroom)	200	160
Swimming pool bathhouses (per person)	10	8
RV / Travel Trailer (Per Space)	50	40
Vet clinics (per animal)	10	8
Construction sites (per worker)	50	40
Youth camps (per camper)	30	24

### III. Site Characteristics

Before doing any detailed design specification, it is necessary to evaluate specific site features. This assessment should include the following:

**A. Site Boundaries:** Most state rules will have regulations on how close drip lines may be placed to property lines, home foundations, and other permanent property features. Follow local rules for set backs from these boundaries.

**B. Special Features:** Community water distribution lines, property and utility easements, wells, treatment systems, water lines from wells etc. require set backs. Surface waters, including ponds, lakes, streams and even Intermittent water courses also require specific set backs, typically 75 feet. Be certain to Follow local regulations for set backs.

**C. Future Land Use Restrictions** The drip field can be installed under a permanent lawn, among trees, or other landscape features, provided set backs are followed. Any future permanent structures that will affect soil texture and water flow through the soil must be avoided over a drip field, including but not limited to the following: out buildings, parking areas, swimming pools, tennis courts, home additions, decks, etc. The designer should consult with the homeowner regarding any anticipated improvements to the property, and avoid these areas.

**D. Precipitation:** If the site is in an area which experiences seasonal, intense, and even short duration precipitation events which cause collection of water from surrounding areas or ponding of water on the soil surface, then special attention should be directed toward regrading the soil surface to encourage direct precipitation run off.

**E. Slopes:** Drip disposal encourages lateral, not just vertical movement throughout the soil. This does not restrict disposal fields to level areas, especially with the use of pressure compensating emitters and zoning. However, it will increase the amount of land needed depending on the severity of the slope. The following chart, from the State of Virginia, demonstrates that considerations of slope must include information about the soil depth. Additional considerations about slopes include

- 1) whether there is a natural or artificial barrier down slope from the proposed site that might provide opportunities for water to surface (such as hill side cuts or walls),
- 2) whether the drip tubing can be laid out on the contours of the slope, and
- 3) whether the design can incorporate air release valves, check valves, zones, and other means to equalize flow and to prevent drainbacks.

Absorption Area Increase (percent)				
Depth to Impervious (Rock, pans, etc.)	Slope of Site (percentage)			
	10 to 19	20 to 29	30 to 39	40 to 50
Drip Tubing, 24" off Impervious strata	17%	33%	50%	67%
Drip Tubing 24" or more off impervious strata	0%	17%	33%	50%

**G. Prior Land Use:** Research should be conducted to determine if there were any prior activities on the proposed site that would affect soil characteristics. These effects include compaction, foreign soils, buried materials, etc.

With consideration of the above issues, and any similar issues that the designer believes may affect soil absorption rates, the designer is ready to evaluate the specific soil characteristics.

## IV. Soil Absorption

After the drip disposal area has been identified, the designer must undertake a thorough study of the specific soil characteristics of the proposed field. Particular focus must be given to Texture, Loading Rates, Native vs. Disturbed Soils, and Restrictive layers.

### A. Sample Collection

An accurate representation of the overall site conditions requires a determination of the underlying soil characteristics. A minimum of 2 samples per proposed zone is necessary. The sample shall be a three dimensional soil core

sample which extends into the soil a minimum of 2 feet deeper than the proposed location for the drip tubing. The analysis of the soil core should not only be for the texture, but should include analysis for presence of ground water, seasonal high water tables, restrictive layers, etc. USDA/NRCS Soils Maps or other locally available geological maps should be consulted to determine consistency between observed and referenced conditions. Any inconsistencies should lead the designer to undertake further investigations of the site particulars and history.

**B. Soils and Site Characteristics:** The following USDA Chart should serve as an outline to determine soil composition, therefore texture and suggested loading rates.

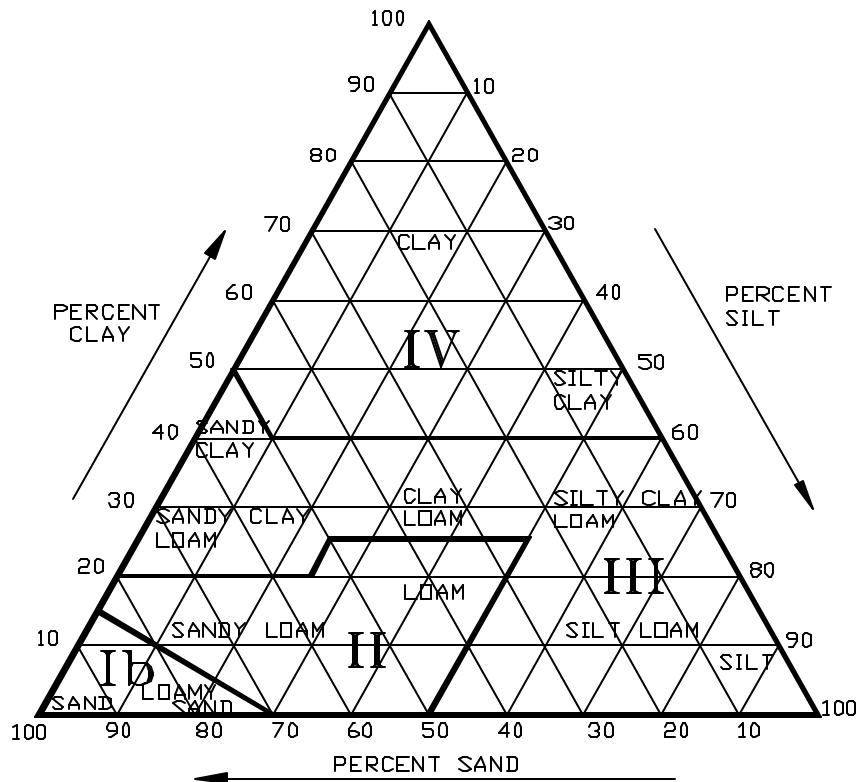

#### SOIL PARTICLE SIZE:

Clay - Smaller than 0.002 mm in diameter.

Silt - 0.05 to 0.002 mm in diameter.

Sand - 2.0 to 0.05 mm in diameter.

Gravel - Greater than 2.0 mm in diameter.

mm = millimeter

Note 1: Sand shall be free of organic matter and shall be composed of silica, quartz, mica, or any other stable mineral.

Note 2: Class Ia soils contain more than 30% gravel, therefore, they are not portrayed on the soil triangle.

### C. Determining Soil Texture

Accurate analysis of several samples collected across the proposed site area is critical to determining the absorptive capacity of the soil. The designer must locate the soil on the USDA Soil Chart to establish the soil classification. If the samples from the different locations of the proposed site are different, the design must be based on the most restrictive sample. The system designer should always consult with a Registered Soil Scientist, Site Evaluator or Soils Structure Laboratory for assistance in determining an accurate soil texture classification.

### D. Restrictive Layers

Many soil environments are surrounded by other soils with less desirable characteristics. It should be recognized that water movement through multiple soil types will be determined by the characteristics of the most restrictive types. Therefore, whenever these restrictive types are encountered in a proposed drip field, they should provide the operative design criteria. In particular, soil absorptive capacities should be based on those of restrictive layers rather than those of the more absorptive soils. If restrictive layers are present within two feet below the drip line, then the designer should use the reduced loading rates of the restrictive layer to prevent system failure. The greater the soil depth to a restrictive layer, the better.

In the two to four foot range below the drip tubing, if there is a change in the soil classification of one unit or more, or if a boundary layer is present (rock, tight clays, etc.), then the disposal area must be increased to prevent failure.

### E. Native vs. Disturbed Soils

Native, non-disturbed soils are always the most desirable medium for drip application. However, if the soils are very poor, or the site conditions (e.g., available space) are so limited, then the designer can consider the introduction of fill material.

If the proposed drip field employs fill material, artificially compacted soils, or mixed soils, special considerations apply. Although the fill material may have a greater soil absorptive capacity, a design should not rely on the better soil classification if the underlying poor soil is still present and utilized in the drip system design. Mixing or tilling of the soils may increase the soil absorptive capacity. However, adding Class II soils to a Class IV site does **NOT** yield a Class III absorptive capacity. A proper analysis by a soils laboratory (engineering rather than agricultural focus) is necessary to determine the new soil characteristics. Any time a drip field is constructed with added soil, the overall field should be larger than called for in the design, and the loading rate should be determined by the restrictive layers rather than by the constructed soils.

The following “soup bowl” configuration demonstrates the problem. If the bowl area is scooped out and replaced with more absorptive soils, system failures may still occur because the water will be trapped in the bowl. Conversely, if the situation is reversed, in a “mound” configuration, water will tend to escape at the

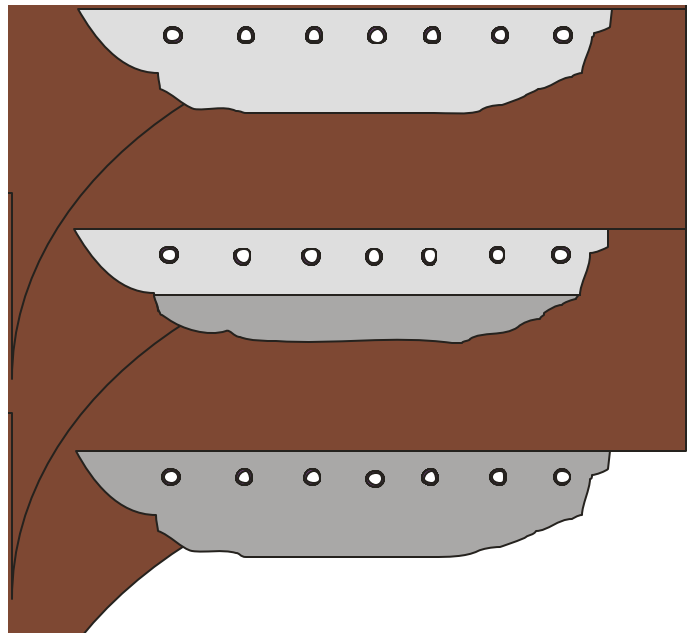

interface between the imported and native soils. With the above constraints used to define the overall characteristics of the proposed drip disposal site, the designer is now prepared to es-

## V. Soil Hydraulic Loading Rate

The maximum hydraulic loading per unit area of soil is determined by the soil texture classification. Different soil textures have different porosities and therefore enable different quantities of water to pass through the soil. In drip disposal, the goal is shallow disposal, not deep percolation or surfacing. Therefore soil textures at the surface and at depth are important to enable wastewater flow both horizontally and vertically. The key to successful drip system design is to load the soil at an even rate near the surface, therefore promoting plant uptake and evapotranspiration. The recommended loading rates for each soil classification are as follows:

Some states have regulations specifying loading rates that are sometimes more restrictive and sometimes more generous than the above. The designer must follow regulations, but otherwise should opt for more conservative designs.

The basic rule for drip disposal area is:

$$\text{Application Area} = \text{Daily Flow} / \text{Loading Rate}$$

Variations in the recommended rates enable the designer to take account of special circumstances, such as vegetation, precipitation, wind, or other factors that can remove water from the immediate vicinity of the drip emitter. In all cases, using the higher application rate may result in a system failure. When it comes to design, the more conservative the approach, the better. Remember, the least expensive part of the overall drip system is the tubing.

**Default:** The designer should take into account that the proposed loading rates are for optimal soil conditions, and any of the above mentioned constraints, including but not limited to: Special Features, Precipitation, Slopes, Prior and Adjacent Land Uses, Impervious Boundaries, etc. must be considered in the design. When in doubt, always default to lower application rates.



Soils Range From Class I Sandy soils



to Class IV Tight, Restrictive, Clays.

Soil Classification	Recommended Loading Rate (gal/sq. ft)	Maximum Loading Rate (gal/sq. ft)
I	0.5	1.5
II	0.25	0.3
III	0.15	0.2
IV	0.05	0.1

## VI. A. System Design

The following discussion describes the key mechanical elements of the overall drip system. A simple schematic design for onsite wastewater disposal using drip is follows:

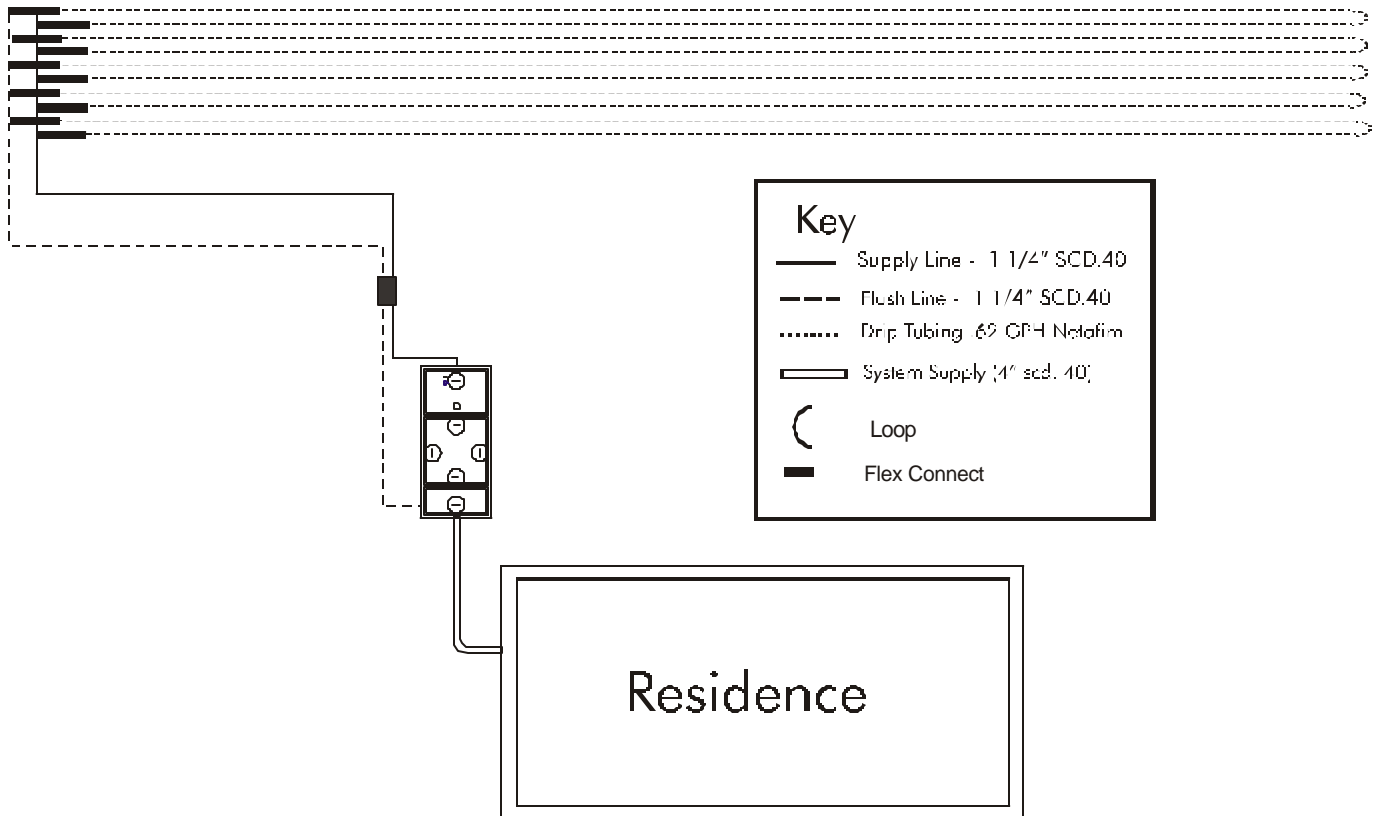

## VI. B. Components

**Pump:** Although systems can be designed to use most any commercially available pressure pump, the Hoot Blaster 20EB is the supplied pump for these systems. Its curve is optimal for the drip systems, capable of delivering high volumes of water for creating scouring velocity, and a low enough maximum pressure, even under dead head conditions, to prevent damage to components, fittings and tubing.

**Storage:** An operating storage capacity in the storage tank behind the treatment unit to allow for flow equalization and emergency storage. The operating capacity should be designed to hold a minimum of 18 hours of normal flow to allow for even distribution to the drip field throughout the day. Additionally, an emergency or reserve capacity should be established which will allow for temporary excess flow, or in the case of equipment failure, time for service or repair personnel to arrive. There should be a minimum of one-half day storage above the high water alarm, but circumstances may dictate higher storage capacity.

**Filtration:** Every drip system must include a filter to prevent introduction of sediments and suspended organic materials into the drip tubing that might accumulate over time and cause plugging. A 100 Micron Disc Filter is typical, allowing for filtration of particles 7 times smaller than the maximum sized particle the emitter can pass.

## VI. B. Components—cont.

**Vacuum Relief:** A critical feature in drip system design is a minimum of two vacuum relief valves per zone. Their purpose is to prevent soil particles from being sucked back into the drip emitters when the system is depressurized. They should be located at the highest point on both the distribution and return manifolds. They should be located in an irrigation or valve box, lined with a pea gravel bed of at least 6 inches.

**Pressure Regulation:** With the use of Pressure compensating drip emitters and appropriately sized pumps, it is not normally necessary to regulate pressure. A normal field operating pressure should not exceed 45 psi, with a recommended range of 25 –40 psi. The Netafim Bioline is designed to provide uniform drip output rates with pressures of 7 to 70 psi at the emitter.

**Check Valves:** Check valves are necessary to prevent backflow and to isolate zones. In multiple zone systems, each zone should have a check valve at the distribution and return manifolds.

**Loops and Flex Connects:** Loops and flex connects are made of flexible PVC with a Spin Lock connector. They are used to prevent kinking of Bioline tubing. Kinking can completely shut off flow through the drip tube, therefore eliminating its usefulness. Loops should be used in any circumstance where greater than a 45 degree turn must be made. Flex connects must be used between the Bioline tubing and the manifold to allow for shrink and swell and the movement and settling of the soils.

**Supply line:** The standard design is a 1 ¼” high pressure line made of schedule 40 PVC from the filter to the supply manifold. It should contain a minimum of 1 check valve to prevent back flow into the tank. The check valve located on top of the Hoot Blaster is sufficient if the system has only one zone. Each zone needs its own check valve in multi zone systems.

**Supply Manifold:** The standard design is 1 ¼” PVC piping where the supply enters and is distributed to the tubing via the flex connections. To maintain both a volume and pressure of effluent to achieve scouring velocity for field flushing, the number of connections to the manifolds must be limited. See chart on page 10 for maximum number of connections to each manifold.

**Tubing:** Through the tubing is where water distribution into the soil occurs. The effluent leaves the tubing at 0 psi, through pressure compensating emitters, designed to produce a flow rate of 0.9 gallons per hour (gph) The limited flow rate is designed to prevent over loading of the soil.

**Return Manifold:** The characteristics of the return manifold are the same as the supply, with a limited and equal number of connections. It is recommended to maintain the same diameter pipe size as the supply to limit any possible restrictions.

**Flush line:** This component should be made of the same diameter of pipe as the return manifold. It terminates at the front end of the treatment system (pre-treatment tank). **If disinfection is utilized on the system, the flush line must return to the pump tank or the system will be disrupted by the disinfection agents.** It shall have, at a convenient location, a manual or electric valve to enable flow only during field flushing.

## VI. C. Zone Requirements

**Maximum Zone Size** - If flows exceed 10 G.P.M., or if there are significant topographic or other site constraints, it is recommended that multiple zones be considered in order to have sufficient system capacity for field flushing. For the longevity of the tubing, from time to time field flushing is necessary to keep the emitters and the tubing clear of sediments. For the most cost effective results, the designer should consider the use of mechanical valve such as the Hydrotek, to dose different zones.

Drip Tube Type	Maximum Tubing Length per Zone			
	with 5 Connections	with 6 Connections	with 7 Connections	with 8 Connections
.4 GPH	2000 feet	1685 feet	1370 feet	1055 feet
.6 GPH	2000 feet	1685 feet	1370 feet	1055 feet
.9 GPH	1250 feet	1042 feet	834 feet	626 feet

Flows exceeding 10 G.P.M. per zone require specialized pumps, higher voltage, and contactors and motor starters. At this time, the Hoot Drip control panel cannot control these pumps and therefore, these pumps are not recommended in this design guide.

If utilizing limited soils, or designs that require larger drainfields, zones can be increased to 2000 linear feet utilizing either the .6 and .4 gph tubing.

## VI D. Piping Layout

The basic principle of field layout is to arrange the tubing so that drip tube laterals are roughly equal and approximately 300 to 400 feet in length. Lengths greater than 400 feet will require pumps to create more head and flow than are typically available from 1/2 horse power pumps. Horizontal spacing between tubes of 24 inches is standard practice.

A standard, recommended pipe size to optimize flow and friction loss for drip distribution systems up to 5000 gallons per day is 1 1/4 inch PVC for distribution lines, supply and return manifolds, and return lines.

## VII. Operational Design Principles

In addition to describing the key system components, it is necessary to discuss fundamental operational principles. These pertain to dosing, filtration, field flushing, and control of root intrusion.

### A. Dosing and Controls

The fundamental principle of drip distribution is to take full advantage of the entire application area, over the course of the entire day. Although most wastewater flows have peaks and valleys, the goals of effective distribution are to:

Keep soil moist  
Encourage lateral (i. e., capillary) rather than gravitational flow  
Spread the effluent out over the field, and  
Utilize the entire 24 hour day.

All of these goals are accomplished through effective dosing controls. A sophisticated dosing system is especially important on tight, shrink-swell soils, since they are very sensitive to overloading.

With an effective design, the drip disposal system provides water in the root zone for plant uptake. Plant uptake increases the soil absorptive capacity through evapotranspiration.

The function and complexity of the control system will be determined both by the wastewater demand and the limitations of the soil. The control system needs to take into account:

- Unusual loading conditions
- Storage Capacity
- Emergency storage/malfunction
- Sizing limitations (as discussed above).

A simple demand system configuration will generally not be adequate; for example, a float switch with a 100 gallon tether. The system must have adequate capacity to receive the flow and distribute it evenly over the course of the day, rather than merely distribute the effluent as it enters the pump tank.

Historically, the cause of most drip system failures is not improperly designed drip fields, but rather an inadequate soil loading schedule. Experience has shown that even a flow as little as 200 gallons, dosed intensively, can cause a system failure in the same field that could accept 500 gallons, if dosed evenly throughout the day.

## How to Dose

The following analysis, provided in the attached computer program, provides the conceptual basis for sizing the drip field, setting up zones, and designing the pump control system for delivering the desired quantities of wastewater to the desired places over the desired time periods.

1. How many Gallons Per Day is the Wastewater load? (See Page 3)
2. What is the Soil loading Rate? (Check local Rules)
3. Calculate Disposal Area. (G.P.D./Loading Rate = Application Area)
4. Calculate linear length of tubing (assumes 24" between lines)
5. Select dripper flow rate and spacing based on soil type.
6. Calculate Total Flow Rate of all tubing
7. Determine # of Zones needed by pump size consideration (zones should not exceed half the rated volume of the pump)
8. Calculate total flow rate per zone GPM
9. Calculate # minutes of run time based on daily flow
10. Calculate # of minutes per zone (total min/zones)
11. Select dosing duration based on soil conditions (6 to 12 minutes) to determine # of dosing events.
12. Calculate time between dosing events (Based on an 18 hour day)

**In addition to turning the pump on and off at specified times to achieve the desired distribution of water, the control system must enable cleaning of filters and field flush, manually, electronically, or automatically.**



# Manual Design Calculator

Job Name/Homeowner:	<u>John and Jane Doe</u>
Address:	<u>123 Main Street</u>
City, State, Zip:	<u>Anytown, USA 45678</u>
Permit Agency:	<u>County Health Dept.</u>
Installer Name:	<u>Joe's Septic Service</u>
Designed By:	<u>Walt Johnson, P.E.</u>
Date:	<u>7/4/2002</u>

Gallons Per Day	300
Soil Loading Rate (GPD, Per Sq. Ft.)	0.2
Select drip rate	0.61
Emitter Spacing	24
Desired Dose Time	12
# of Zones	1

Note: Maximum zone size is 2000 linear feet of tubing

Square feet of Application Area	1500
Linear Feet of Tubing	750
Number of Emitters	375
Linear Feet of Tubing Per Zone	750
Emitters Per Zone	375
Drip Rate (GPH)	0.61
Gallons Per Minute Per Zone	3.8
Minutes Per Day Per Zone	79
Doses per Zone	7
Total Doses per Day	7
Time Between Doses in Hours	3.0
Total Run time in Minutes	79
Maximum Connections to Manifold	8

## B. Filter Cleaning

The filter on the system is designed to capture particles larger than what can safely pass through the drip emitter. Over time, particles will build up and cause the filter to clog. There are several filtration systems and methods that can be used to clean and restore the filter to normal flow.

**Manual Filter:** a filter in the feed line coming from the treatment system. Cleaning it requires the filter cartridge to be removed, and the rings and housing to be manually flushed with water.

**Timed Back Flush:** This is a more sophisticated filtration system which normally has several filters and valves used in a configuration to clean one another automatically. The frequency of the back wash is controlled using a time clock or dosing counter to automatically flush the filter. Filtered water is sent through another filter backwards, therefore dislodging particles captured between the filter rings. This backwash water is then returned to the treatment system and reprocessed.

**Default:** All systems from time to time will need cleaning. If the system has a manual or automatic timed back flush, manual cleaning of the filter cartridge and rings will still be needed occasionally. Especially as a treatment and disposal system is first started up, cleaning will be necessary to insure that construction debris is removed before it can lodge in the sensitive drip emitter elements.

**Filter Cleaning:** All filters from time to time require that the filter be taken apart and cleaned out. Each disk surface has grooves that capture particles as they try to pass through the filter. Therefore, it is necessary to separate the disks and clean each surface to truly clean the filter. This is accomplished by using water under pressure to wash the surfaces of each disk, not only the outside of the cartridge. For deposits that have formed on the disks and cannot be removed by mechanical means, muriatic acid should be used (in a 10:1 ratio of water to acid, following safety instructions on the acid container).

## C. Field Flush

Drip tubing is designed to last the lifetime of the system. Although filtration is taking place, small particles (under 100 microns) can still enter the tubing. These particles are generally 7 times smaller, as a maximum, than the size the emitter can pass. However, over time these particles can accumulate. Therefore, occasionally it is necessary to field flush the system.

Field flushing is accomplished by opening the return line from the drip field to the pre-treatment tank. In this process, the velocity of water moving through the tubing must be at least 2 feet per second. To prevent plugging of the emitters, it is recommended that field flushing take place on a regular basis. Field flushing should be done at least several times per year, but the required rate will depend on many factors. Among these are:

- Length of tubing in each zone
- Frequency of dosing each zone
- Effluent quality and characteristics
- Filtration Efficiency

## VIII. Installation of System

### HOOT Aerobic Treatment System

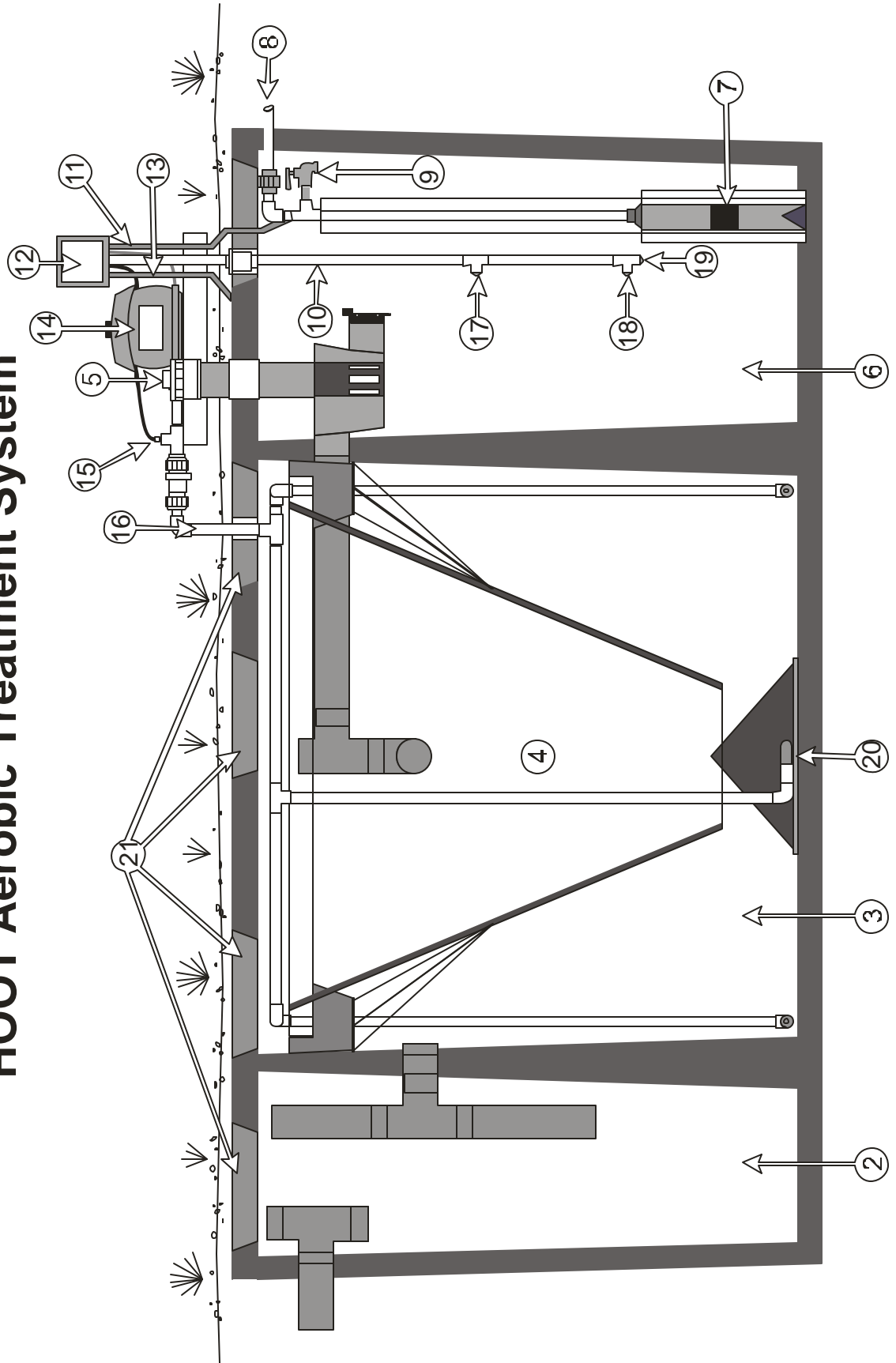

## The HOOT Aerobic Treatment System Diagram

- |                         |                         |                      |
|-------------------------|-------------------------|----------------------|
| 1. Inlet                | 8. Pump line out        | 15. Air Manifold     |
| 2. Pretreatment Tank    | 9. Control valve        | 16. Aeration line    |
| 3. Aeration Chamber     | 10. Probe               | 17. High Water Probe |
| 4. Clarifier            | 11. Pump wire           | 18. Low Water Probe  |
| 5. Optional Chlorinator | 12. System Controller   | 19. Probe Ground     |
| 6. Pump Tank            | 13. Power Line (20 amp) | 20. Aeration Stone   |
| 7. Hoot Blaster Pump    | 14. Linear Air Pump     | 21. 15" Covers       |

## Tank Installation Instructions

1. See Tank dimensions section and dig hole approximately one foot larger than the tank all the way around - proper grade with smooth and level bottom.
2. Fill out Installation and Delivery Tracking Form. Driver will not leave tank at jobsite until this filled out.
3. Delivery driver will place tank in hole - and confirm it is level within 1 inch from center of tank to any corner.
4. Connect inlet into the Pre-Treatment Tank, and place filter system on top of the pump tank riser, back-fill with dirt and fill tank with water.
5. Bring required access ports to grade.
6. Follow the instructions for the System Controller Installation.
7. Hook up blower plumbing - including sensor line to the Aeration Tee.
8. Hook up water pump to drip filter system.
9. Place cover over aerator - be sure not to pinch air line.
10. Power up system - it is ready to accept sewage.
11. Fill in Warranty Registration and Service Policy, and give to homeowner.

## SPECIAL INSTRUCTIONS - PLEASE NOTE!

HOUSE WIRING MUST HAVE 30 AMP INDEPENDENT BREAKER AND MUST MEET NATIONAL - STATE - AND LOCAL REGULATIONS. INSTALLATION AND OPERATION MUST BE IN COMPLIANCE WITH STATE WATER REGULATIONS, COUNTY AND LOCAL PLUMBING AND ELECTRICAL CODES.

FAILURE TO COMPLY TO THE INSTRUCTIONS FOR THE INSTALLATION OF THE TANK AND THE SYSTEM CONTROLLER WILL VOID ANY AND ALL WARRANTIES PROVIDED BY HOOT AEROBIC SYSTEMS, INC., AND WILL PLACE THE BURDEN OF WARRANTY COVERAGE ON THE INSTALLER. FAILURE TO FOLLOW INSTALLATION INSTRUCTIONS PROPERLY MAY CAUSE SERIOUS INJURY, ILLNESS, OR DEATH TO PERSONS AND MAY CAUSE SERIOUS DAMAGE TO THE HOOT SYSTEM AND OTHER PROPERTY.

# HOOT System Controller

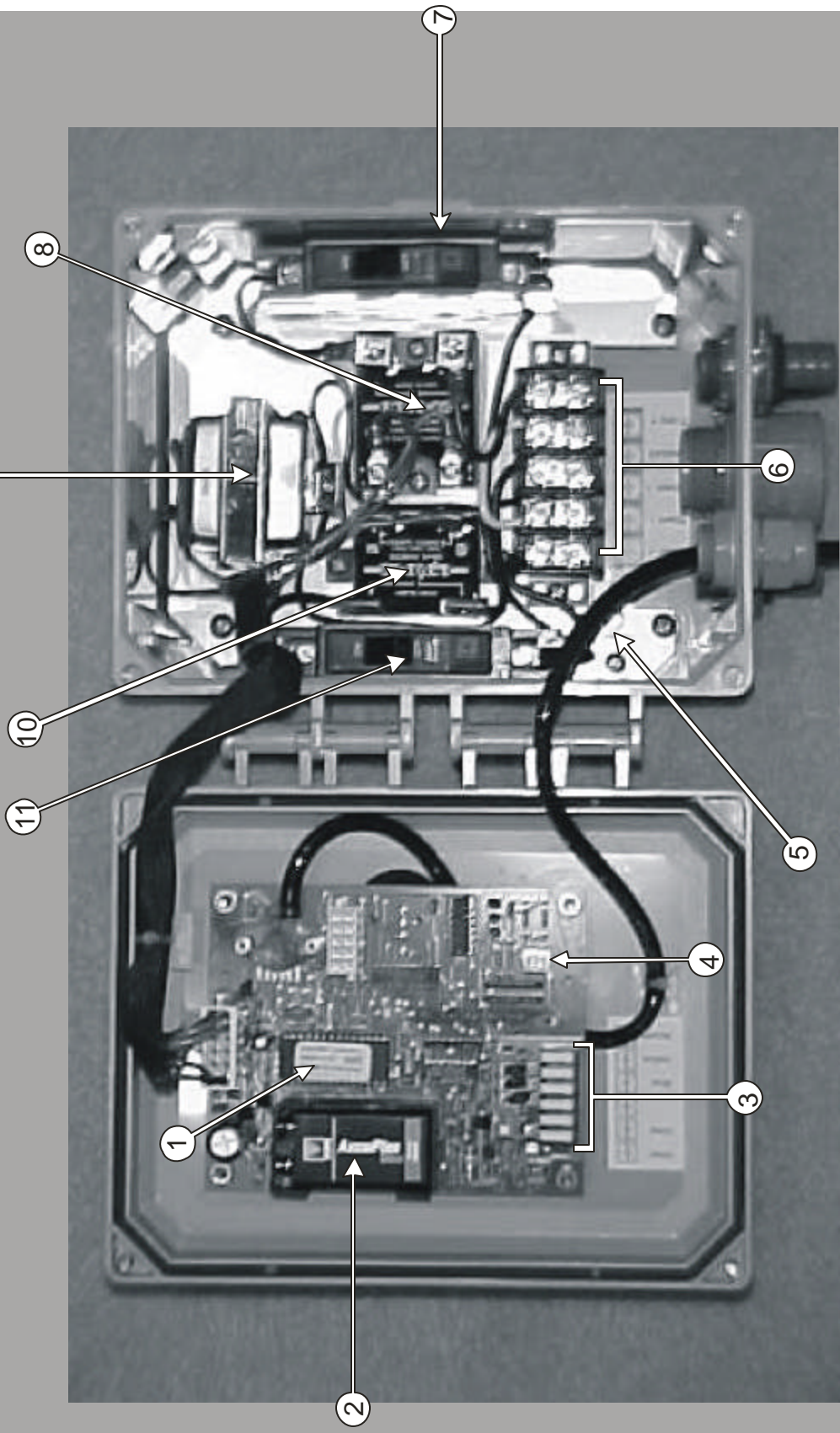

## System Controller Diagram

1. Controller Chip
2. Nickel Metal Hydride 9 volt battery
3. Probe & CL hook-up
4. Dip Switches
5. Grounding Lug
6. Terminal Strip
7. 20 Amp Water Pump Breaker
8. 45 Amp Water Pump Relay
9. Transformer
10. Aeration Relay
11. 15 Amp Aeration Breaker

**\*A 30 Amp Service Box** - within sight of the unit, must be provided by the homeowner before the unit can be installed. Installer must have a qualified electrician bring a line out to the area where the unit is being installed for hook-up.

## Detailed Hook Up Instructions

1. Unscrew the two screws securing the cover of the box.
2. Determine and cut the length of 1" PVC Conduit needed so that the box will be mounted taller than the blower housing. (For remote mount, see instructions on Page XXX)
3. Cut the conduit and glue it to the probe base on the Tank - feeding the probe wires through.
4. Mount the controller box to the top of the 1" conduit, feeding the probe wires through into the box.
5. Cut the probe wires so that there is approx. 12 inches of wire coming out of the box.
6. Strip back each of the wires, lift lever and insert wires according to the sticker under the board.
7. Feed the aerator cord through the compression connector, through the flex conduit and into the box. Then screw conduit into the connector on the box and glue conduit to compression adapter. Pull wire into the box, leaving approx. 1" of wire between the end of the conduit and the blower.
8. Connect the black wire to the + Blower screw on the terminal strip .
9. Bring the water pump wires and solenoid wires through flex conduit, screw flex conduit into the connector on the bottom of the box, then fill the stub on the tank, and each end of the flex conduit with Silicone II.(Failure Silicone II flex pipe will void the warranty!)
10. Connect one of the black pump wires + Pump screw on the terminal strip.
11. Connect solenoid wires to the loose wires marked "Field Flush Solenoid"
12. Make sure 30 amp circuit breaker,(power from house, supplied by owner) is turned off.
13. Bring the power wire through flex conduit, screw conduit into the connector on the box and fill each end of the flex conduit with Silicone II (failure to Silicone II flex pipe will void the warranty!)
14. Connect the hot wire (+) to space provided on the terminal strip.
15. Connect the neutral (-) from power line to the space provided on the terminal strip.
16. Connect the 2<sup>nd</sup> water pump wire and aerator to the neutrals space on the terminal strip.
17. Connect the ground from the power line, sprinkler pump and aerator to the grounding lug.
18. Turn both breakers in control box off, then on again to reset.
19. Hook up black air line to the brass compression fitting on the aeration tee.
20. Turn on 30 amp breaker at the house
21. Install the 9 volt battery into the connector on the board.
22. Re-install cover with the two screws, do not use screw gun or box damage may occur.
23. Turn Control box so that it faces the house or driveway.

## Installation Instructions for System Controller

### Electrical Hook-Up

Connect the Hot Lead (+) from 30 Amp service provided to the system and the Neutral (-) to the Terminal strip located in the bottom of the box.

All of the grounds (from house, aerator, and water pump) are hooked up to the grounding lug located in the bottom left hand corner of the control box. To hook-up the grounds, it is easiest if you unscrew the lug from the metal plate, twist your wires together, insert them in the grounding lug, and tighten. Then re-install the ground lug using the Phillips screw you just removed.

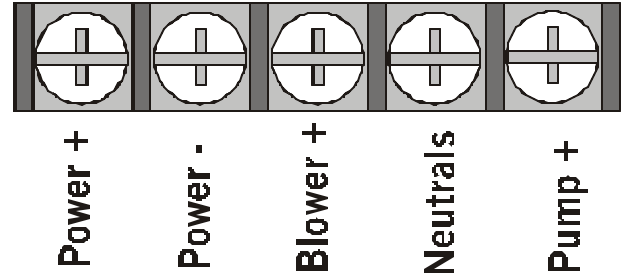

### Component Mounting

All of the components in the box are surface mounted to an aluminum heat sink that covers the entire back of the box. They are all mounted using #8 self-tapping Phillips head sheet metal screws. The metal plate is fastened to the box using #10 x 32 machine screws and can be removed entirely from the box if you feel necessary.

### Board Hook-Up

The only wires that get hooked to the board are the probe wires. From left to right the wires are hooked up in this order:

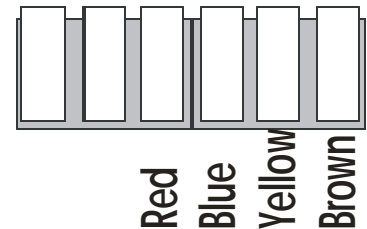

### Battery Back-Up

Our system has a battery back-up for a power failure alarm. The battery even maintains the correct pump out time even in the event of a temporary power failure. The system will pump long as the system is receiving power from the house at its scheduled pump out time. The battery is a long life rechargeable nickel metal hydride battery, is charged by the board and can be charged indefinitely at the charge level used and should last several years. You cannot replace the battery with any type of battery except what is provided or damage will occur. The battery indicates a power failure by flashing the red **SYSTEM ALARM** light and beeping the beeper. To silence alarm, simply push the red **SILENCE ALARM** button. This will silence the alarm until power is restored or the battery loses its charge. With the power from the house off, the controller can indicate battery strength. With the main power off the controller sounds a chirp and flashes the system alarm once a second, if the battery is charged above 8 volts. As the battery discharges below 8 volts the flash/chirp changes to once every 2 seconds and below 7 volts once every 4 seconds. If the battery voltage is below 5.5 volts there will be no alarm.

If the system is not left running when you leave the job site, and must be powered down until move in, leave the battery installed and silence the alarm. A new battery, not charged, will go dead in a few hours to a day at the most. If the battery has been fully charged (48 hours) in approximately five to seven days if the power is not turned on, the battery will go below 5.5 volts and cease to flash the alarm light. When power is applied to the controller, the board immediately starts charging the battery and will have it fully charged within 48 hours. When the board starts charging the battery, it will beep and flash for up to 5 minutes until the voltage has reached above 7 volts and the computer sees that it is charging. If the battery is not present at start up, the system will come on with a green **SYSTEM OK** light and will sound the alarm and flash the red **SYSTEM ALARM** light. To silence alarm, simply push the **SILENCE ALARM** button and it will remain silenced, indefinitely. The red system alarm light will continue to flash until a rechargeable nickel metal hydride battery has been installed and allowed to charge. To prevent a unnecessary service call, install the battery before you leave the job site. Since the computer is backed up by the battery, it is necessary to remove the battery any time your work on the board. Stray wires or tools could short out or trip up the computer if they come in contact with the board. Powering down the controller is not enough. All normal errors will be cleared by powering down, however, if you see an error not mentioned in the installers manual, reset the board by removing the battery, wait 5 seconds then replace it. Failure to do so could short out the board chip or other components and will not be covered by the warranty. If you are working on the board, remove the battery and you won't have a problem.

It is not necessary to replace a battery unless it will no longer hold a charge. Only replace the battery with a nickel metal hydride battery provided by HOOT or a HOOT authorized manufacturer or distributor. The charging circuit will ruin a standard carbon-zinc or alkaline battery very quickly and may make it leak on the circuit board. Nine-volt nickel cadmium batteries are really 7.2-volts, and are not designed to charge indefinitely. Even a nickel metal hydride battery purchased at a local electronics dealer will not work because they are also 7.2 volts and the battery back up will only function for a few hours, not the many days necessary for this function. Any returned boards containing battery leakage damage must be returned with the battery installed. Failure to do so will result in no warranty credit for the board and you will be charged its full replacement price.

### **Blower Cord Protection**

Included with the control panel is an additional three feet of flex conduit for the protection of the blower cord from weed-eaters, etc. Included with the flex conduit is a female slip by female

The coupling and cord grip are slipped onto the aerator cord first followed by the piece of flexible conduit. Feed the aerator cord through the liquid tight flex conduit connector on the front of the box and screw flex conduit into the connector. Draw the cord tight so there is approximately one inch of cord between the end of the Heyco connector and the aerator. Do not let Heyco connector butt up against the aerator, this could cause excessive vibration and failure to the seal on the blower and vibration inside the panel.



## Start Up Procedure

Fill tank by running water into the aeration tank until it fills both the pretreatment tank and raises the water level in the pump tank to at least one foot above the pump. Failure to fill tank in this manner will result in an aeration problem within 30 seconds after start-up. Install battery and power up controller. The green system okay light will flash during the first 20 seconds while the aerator is pressurizing the system. If after 20 seconds the pressure switch indicates low air pressure the **SYSTEM ALARM** light along with **AERATION PROBLEM** light will come on. This indicates that either the center tank is not full, switch #1 is in the on position or you have a problem with the aeration plumbing. See installer manual for additional help with trouble shooting.

With a green **SYSTEM OK** light on, if you get a solid, or flashing with beeping **AERATION PROBLEM** light, this indicates high aeration pressure. If this occurs after start up, this could indicate clogged stones, or the system needs pumped out. If you get a **SYSTEM ALARM** light along with fast flashing **AERATION PROBLEM** check to see if check valve is backwards.

If after first 20 seconds of operation you get an audible alarm with a solid green **SYSTEM OK** light and a chirping alarm and flashing red **SYSTEM ALARM** light, the battery has not been installed, or is completely dead. Either install the battery or allow the battery to charge. If the battery has been installed, the alarm will go off in less than 5 minutes. In either case, silence the alarm, and the **SYSTEM ALARM** light will continue to flash indefinitely. When the battery reaches 7 volts, alarm & light will clear.

## Chip Replacement or Board Work

If it is ever necessary to work on the board (ie: Making connections to probes, for chip replacement, etc.) it is necessary to both power down the controller and remove the battery. Failure to do so will short out the board, components or the chip and will not be covered by warranty. If you are working on the board, remove the battery and you won't have a problem.

## Aeration Sensor

The controller has a solid-state pressure sensor. This sensor has no moving parts and has a silicone seal internally against moisture and gases. Using this sensor, the controller can measure the air pressure on the Hoot system, and will warn of low or high air pressure. The low air pressure indication is a Red **SYSTEM ALARM** light and a yellow **AERATION PROBLEM** with a beeping alarm. If this occurs during startup, likely your aeration tank is not filled with water. Back pressure cannot be maintained if there is no water in the system. This is a system failure and the controller will shut down the air pump and the pump tank is emptied one time. This will shut down the controller system until reset by powering down and back up.

The high air pressure indication is a Red **SYSTEM ALARM** and a flashing aeration light. If the pump is dead headed (check valve in backwards or the stones are completely blocked) the red **SYSTEM ALARM** light is on with a Fast Flashing **AERATION PROBLEM** and beeping alarm. This will shut down the air pump to prevent damage to the pump. It will take 4 minutes of run time to create this alarm to confirm that it is not simply water that has infiltrated the drop lines during assembly or during a power outage

### **If a high air pressure alarm occurs after a week or two of initial operation**

A slime coating on the aeration stones may be causing the problem. Once the bacteria flock has had time to establish itself the stones will clear and the air pressure should normalize. This could happen to systems that have been left in the ground and the homeowner begins use prior to system start-up. Follow the stone flush method to clear the stones. If the alarm reoccurs, then there is a serious restriction, likely there has been a large amount of infiltration occurring on the system and the bottom of the tank has filled with dirt, sand or mud.

After the flock is established you can use the pressure switch as a reference point to determine the solid level in the tank. Do a settleable solids test on a sample from the aeration chamber. If after 45 minutes you still have greater than 85% solids, the system needs pumped out. You should also be able to observe carry over of solids in the pump tank. If this is not the problem, as a last resort remove and clean or replace the aeration stones.

## To Create a Water Level Problem for Inspection

To Create a **WATER LEVEL PROBLEM** for inspection: Fill the pump tank to the level of the Alarm Probe. This is the top sensor (3) on the probe (filling the system to the mid probe (2) will do nothing but adjust the timing). Disconnect the pump from the drip field or turn off the breaker that operates the pump to ensure the level will not drop below the Alarm probe while this test is in process. While water is present over the top probe, power up the system, holding the **SILENCE ALARM** switch. This will disable the Field Conditioning software. Release the button within the first eight seconds and the light should go from **SYSTEM ALARM** Steady Red to the **SYSTEM OK** flashing green light for 20 seconds. When the green light goes steady, the pump will turn on and run the pump for 4 minutes, jog the pump ten times, then run for 6 additional minutes. If it has still not lowered below the Alarm probe, then you will get a **SYSTEM ALARM** and **WATER LEVEL PROBLEM** light.

## How to Empty A Pump Tank

With a drip system you cannot dump the entire tank to the drip field. The software won't let you do it and if you hot wire the panel you will ruin the drip field. Try to prevent this situation at start up by watching tank fill, or by leaving the system running when you leave. If the tank gets filled prior to startup, it must be lowered, but not by adding the effluent to the drip field.

Options to lower the tanks are the following:

1. Have a pump truck come and lower to the operating level. This is a must if the system has been used prior to startup.
2. If you have simply overfilled the tank, then prevent the pumping to the drip field by blocking it off at the disconnect, and force the water out the hose bib connection and remove the water through a series of sprinklers. You could use this water over the field to water it down.

## Creating and Aeration Problem

If you create an **AERATION PROBLEM** by breaking the air line loose, you will get an **SYSTEM ALARM** Red Light and **AERATION PROBLEM** yellow light. The pump however, will continue to operate and load the soil at the scheduled rate, and will ramp up if water level situations occur, etc. until that system fails. The filtration system prevents the introduction of materials to the tubing that could clog the emitters or the field. Once the filter finally clogs, the pump will no longer be able to move effluent out to the field.

## Remote Mounting Kit Instructions

Although Hoot feels the best place for the controls is on top of the tank, we have created a Remote Mount Kit so it can be accomplished correctly. Care must be taken when doing so to ensure equal performance and function. The following guidelines must be followed or problems will result. To avoid problems, correctly follow the steps listed below with no substitutions. If you have any questions please call before proceeding with the installation. These are not only guidelines, they are rules and failure to follow them will be a violation of the ANSI/NSF Standard 40, 1996.

The kit comes with brackets to mount the panel to the house, all fasteners including expansion shields for brick or concrete, a probe with sixty feet of wire, silicone wire nuts, and in line junction boxes. All you will need to complete the remote installation is 12 gauge stranded wire to extend your pump wires, ½" conduit and 1 1/4" air line from the tank to the remote location.

**Blower and Panel** May be mounted a maximum of 50 feet from the system. If the blower is remotely mounted, the panel **MUST** be remotely mounted too, and at a distance of no greater than 5 feet from the blower. The blower needs to go directly into the pressure sensor T and then into the check valve. **YOU MUST RUN 1 1/4" LINE FROM THE CHECK VALVE INTO THE TANK. UNDER NO CIRCUMSTANCES MAY LINE LESS THAN 1 1/4" BE USED ANYWHERE IN THE AERATION DELIVERY SYSTEM UNLESS IT HAS BEEN PROVIDED TO YOU IN THE BLOWER BOX DIRECTLY FROM HOOT.** An essential key to how our system works is through the delivery of the proper volume of air. It cannot be achieved through the use of smaller diameter pipe. If smaller than 1 1/4" pipe is used, less air than the system was tested with will be delivered. This is alteration to the system based on the ANSI/NSF Standard 40, 1996. This would put you in violation of the Standard 40, with Baylor and the FDH.

**Panel** All systems must be able to see the difference between night and day or the timer cannot ramp up dosing during daylight hours. Keep this in mind if remotely mounting a panel and take this into consideration where you locate it. Try to put the panel in a place where it will definitely "see" morning sun, and not a spot light.

**Holes in Box** The control panel has the proper amount of entries into the box. No more, and no less than is needed to operate the system. The Pump and solenoid control wires may run in the same conduit. The power wires can only be run by themselves. The probe wires can only be run by themselves. Any change to the combinations of the wires will result in problems to the control mechanisms and monitoring of the system. The probe wires especially cannot be run with any other wires. They are highly sensitive signal wires and if they are run in the same conduit as the pump, there will be problems with the system.

**Power and Pump Wires** Provided in the kit are 3 silicone filled wire nuts for the extension of the Pump Wires. You will need to provide 12 gauge stranded wire and conduit from the flex connect to the Right Angle Junction box. Once the connections have been made, fill the entire box with silicone, this will act as your stop for gasses from the pump tank.

## Controller Operation

The Drip Controller is a complete integrated set of controls which monitor the system performance and time doses the drip field at pre-set intervals. It controls the air pump, the effluent pump, but is also capable of running additional instructions, such as dosing control and filter and field flushing.

Critical to the process of drip disposal is not overloading the soil. Whether by initially overfilling the tank, the system being shut down after inspection and not turned on until the toilets no longer flush, for many reasons, tanks will get overfilled prior to startup. Please note that once a system has been inspected, legally, it should be left running and this is a must for drip systems. Also, you must be careful to not overfill a drip system over the high probe. Startup on drip systems is critical and if forced to take a completely overfilled tank - the field can ruin on startup. No dose in clay soils should ever go for more than ten (10) minutes at a time, and our recommended run time is just six (6) minutes.

If the system is forced to load the drip field with an overfilled tank, the soil will be hydraulically overloaded. The software won't let you do it and if you hot wire the panel you will ruin the drip field. If you attempt to dump the entire tank, then water will move to the surface, through paths of least resistance. Once the water breaks the surface of the soil, it will always try to break the surface of the soil, and thus cause the system to fail. A failing drip system is defined as one where the effluent reaches the surface of the ground. To prevent this, only small amounts of water, dosed over the entire day will encourage lateral movement, not just vertical movement through the soil.

## Soil Conditioning Mode

Critical to proper drip operation is preparation of the soil and start up of loading. To prep the soil, the tubing can be installed by pulling, knifing or chain trenching it into the ground and backfilling with the material removed from the ground it is recommended that in all in-situ installations, you must compact the soil back into the trench you just created and water the soil from the surface of the soil down. This will help fill in the soil and create a homogeneous structure. If coarse material from the excavation, or a lighter material, such as sandy soil is added to the trenches, water will not move laterally from the emitter, but vertically (see the soup bowl effect in the design guide) and will surface causing a failed system. The Field Conditioning Mode doses the system for the first 24 hours at a rate of 3 minutes every ½ hour to slowly hydrate the soil. This will encourage lateral movement through the soil. To disable this mode, hold the **SILENCE ALARM** switch down while powering up and release after you see the red **SYSTEM ALARM** light, but before 8 seconds goes by. If you go longer, you will put the system into the Trouble Shooting and Status Modes. before 8 seconds goes by. If you go longer, you will put the system into the Trouble Shooting and Status Modes.

## Controller Modes and Troubleshooting

The Controller has several modes to help you service the system. The initial mode is the **Disable Soil Conditioning/Standard Dose**. You can access this mode by resetting the controller, and immediately depressing the silence alarm switch. Release the switch after the lights go out and the first beep. If the water is below the high probe, the green light will flash for 20 seconds, followed by a standard dose for the set amount of run time.

### Resetting the Controller

You can restart the controller by either powering down the system or holding the silence alarm switch for 16 seconds. This works when the green light is on and with some alarm error modes. It will not work if the water pump is running. If the controller will not restart after sixteen seconds you must power off the controller to restart. After the sixteen second timeout, you will hear two quick chirps, release the switch to restart the controller. To enter one of the troubleshooting modes press the switch again before the lights go out on the lamp test and the startup beep. Restarting the controller this way will not clear the error memory.

### Mode 1

The first mode is the **last alarm and system status mode**. You can access this mode by resetting the controller, and immediately depressing the silence alarm switch. Continue holding the switch after the lights go out and the first beep for 8 seconds. When you hear one chirp, release the switch. The controller will check the status of the probes and the photocell. The controller will begin to beep and flash the red light once it is put in this mode, and the number of beeps in a row will indicate the last alarm the system experienced. No alarm is indicated by a single beep. The green light will be on if the photocell is illuminated and off if it's dark (close the door when performing this test to keep light off of the photocell from the rear). The yellow lights are redefined to indicate the probe status. If the probe is wet the light is on and off if dry. The bottom light (add chlorine) is for the low probe, the second from the bottom (aeration problem) is for the mid probe and the third from the bottom (water level problem) is for the high probe. If you press the silence alarm switch and hold until the series of beeps completes its cycle, release the button and the controller will restart.

While the system is in **Status Mode**, you can quickly determine everything is working correctly.

<b>SYSTEM OK</b>	Green Light	Steady if light is present
<b>SYSTEM ALARM</b>	Red Light	Flashing last Alarm Code
<b>WATER LEVEL PROBLEM</b>	Yellow Light	Water Over High Probe
<b>AERATION ALARM</b>	Yellow Light	Water Over Mid Probe
<b>ADD CHLORINE</b>	Yellow Light	Water Over Low Probe

The flash codes are:

- 1=no error
- 4=could not pump below High probe
- 5=could not pump below Low probe (<64 min run)
- 6=photocell error
- 7=water over alarm probe
- 8=low air pressure
- 9=high air pressure
- 10=air pump dead head
- 11=pump jog
- 12=connected to 220 volts
- 13=probe error
- 14=probe circuit failure

If there is no last error indicated, then you may have accidentally cleared the error by:

- Removing the battery and turning off the power
- Harness was plugged in and out too quickly
- No Battery in the system (You will also have a flashing SYSTEM ALARM light)
- Last Error was a power failure
- System was turned off so long that the battery went completely dead

## Mode 2

The next mode is the **force pump run mode**. You can access this mode by resetting the controller, and immediately depressing the silence alarm switch. Continue holding the switch after the lights go out and the first beep for 8 seconds. When you hear one chirp then two chirps release the switch. The controller will start the water pump and the air pump will already be running. The water pump will run for a standard dose or until it clears the low probe, which ever comes first, then restart the controller. This is a good method to find an air leak, as the controller will not power off the air pump, because of low air pressure. Switch off the water pump circuit breaker if you do not need to check the water pump. (Remember to switch the water pump circuit breaker back on if switched off earlier.)

## Mode 3

The third mode is the **chirp/flash air pressure and software version mode**. You can access this mode by resetting the controller, and immediately depressing the silence alarm switch. Continue holding the switch after the lights go out and the first beep for 8 seconds. When you hear one chirp, then two chirps, then three chirps release the switch. The controller will turn on the aeration problem lamp to indicate the air pressure mode and chirp/flash the air pressure in inches of water. For example 65in/water 6 chirps pause 5 chirps long pause repeat. A zero is indicated by a beep instead of a chirp. For example 102in/water chirp pause beep pause 2 chirps long pause repeat. Normal air pressure for a 500 gpd Hoot System is about 65in/water and 78in/water for a 1000 gpd Hoot System.

Press and hold the switch to flash/chirp the software version number. The aeration lamp turns off to indicate this mode. Release the switch to restart the controller.

### **Mode 5**

The last mode is to clear all memory and restart the controller. You can access this mode by resetting the controller, and immediately depressing the silence alarm switch. Continue holding the switch after the lights go out and the first beep for 8 seconds. When you hear one chirp, then two chirps, then three chirps.. When you hear five chirps release the switch. The controller will restart with all memory cleared. This is the same as powering off and removing the battery, then reinstalling the battery and powering back up.

## IX. Installation of Tubing

### A. Site Preparation

To reiterate, the drip field should be viewed as a wastewater disposal field and the limitations of conventional septic drain fields should apply. These limitations should include:

- No future expectation of building(s), decks, or other impervious surfaces
- Limited Number of trees (to avoid root intrusion problems)
- No long term storage of equipment or vehicles over the site
- A permanent vegetative cover.

Grasses dormant in winter must be over seeded with winter grasses when possible. (This factor is critical when designs approach the absorptive capacity of the soil and rely on evapotranspiration for water movement.)

The drip tubing should be installed 8 to 10 inches below the soil surface with an absolute minimum of 6 inches. Remarkably, even drip systems distributing high quality effluent generate enough heat to prevent freezing. Colder climates may require deeper placement to avoid freezing during period of inactivity (see discussion above).

The depth of the manifold trenches should be the same as the tubing depth in order for the vacuum release valves to work effectively.

With each of the following tubing installation methods, it is assumed that the inlet lines and feed manifold and the return lines and return manifold are trenched with a backhoe in order to provide sufficient working room to cut and fit tees and to insert the flex connectors between the manifolds and the tubing.

### B. Drip Tubing Installation

There are three common ways to install the Drip tubing. They are:

1. Trenching: This method uses a commonly available chain trenching machine to cut narrow trenches for tubing installation. The advantages of this method are that these machines are widely available and easy to use. The disadvantages are that the trench may leave wall surfaces that are “slicked” and therefore not receptive to horizontal water flow. The trench must be filled with original materials and watered in from the top down. Failure to do so will lead to premature failure.



2. Pulling: Although a misnomer, pulling refers to the method of knifing, or using a vibratory plow, to insert the drip tubing. This method is increasingly common as the equipment becomes more widely available for such installations. Plowing, or the use of a foot to open a narrow trench is a variant of the pulling approach.



3. Fill: In this method, tubing is laid on the ground and fill material is placed over it. If there is any vegetative cover, it must be removed and the original soil scarified to minimize any inhomogeneity between soil types. If soils of different textures are used, the constraints discussed in the **SOILS** discussion above must apply. . *It is recommended that the fill material be the same as the original, if possible.*



**EVERY EFFORT MUST BE MADE TO AVOID ANY MECHANICAL STRESS ON THE TUBING—BEFORE, DURING, AND AFTER INSTALLATION.**

### C. Piping Hook-up

The supply and return lines, and the supply and return manifolds are installed using standard techniques for PVC piping.

The standard recommended glue is, at a minimum, Medium bodied PVC Cement with Cleaner; however, Heavy Bodied Cement is preferred. It is not recommended to use “Rain or Shine” or “Hot” glue, as these glues are designed for emergency applications where it is not possible to maintain a dry environment. These alternative glues tend to break down faster over time and are less flexible to shrink and swell forces than the recommended glues.

To prevent introduction of PVC filings to the distribution lines, the installer should use a good quality ratcheting type PVC cutter as opposed to a saw of any type.



## X. Operation and Maintenance

The designer should take special precautions to troubleshoot the system and insure that it is working properly over an initial startup period, typically the first month of operation. The Installer should manually clean the filter after the first month of operation. All Aerobic systems have a start-up period where the levels of both TSS and BOD are higher than typical. Once the system establishes itself, the performance level increases, and longer periods between servicing can be used. The filter has been designed to retain solids for a service interval of 6 months between cleaning, after the initial startup.

The State of Oklahoma Requires a service policy for all ATU's at which time the maintenance of the drip system can be conducted. Proper operation of the pump, air release valves, indexing or solenoid valves should be conducted. The filter cartridge should be cleaned mechanically, using high pressure water or be exchanged with another cartridge that has been allowed to soak in either a 10% bleach or Muratic Acid solution.

When a drip distribution system is properly sized, laid out, and installed, it is set up to operate with little maintenance and easy monitoring. In addition to the fundamental design considerations already outlined, several other principles implemented at the installation will simplify maintenance. These are as follows:

1. Provide Schrader valves (tire gauges) on critical piping elements (pump output, supply and return manifolds, etc.) in irrigation boxes.
2. Maintain access to a short length of drip tubing for inspection. Some installers insert a short length of clear PVC pipe in critical locations to enable easy observation of flow, biofilm buildup, etc.
3. Keep a detailed plot plan, system diagram, and wiring diagram readily accessible in a freezer type Ziploc bag located within the filter box.
4. Establish a service record chart to record manual filter cleaning times and pressures at the pump, at feed and return headers, and at the backflush valve.
5. Monitor any changes in the number, activities, and water usage patterns of members of the household.

With this information framework, a system inspector can quickly and easily determine if the system is operating within specifications. If problems are identified by changes in pressure or flow, they can be located and corrected easily using information in the plans and locations of irrigation boxes.

A flow meter is recommended on every system and is a must on systems that are designed near the limits of functionality.

## XI. Chlorine Use with Drip

Drip irrigation is subsurface discharge and has little or no human contact potential. Just like every other subsurface discharge system (including through field lines, infiltrator panels, L.P.D.) there is no requirement for disinfection.

There are certain circumstances that may require disinfection. These would be limited to Installations near surface or ground waters.

Even with highly pre-treated effluent, the soil is capable of degrading the organic and biological matter still present in the effluent even further. The disinfection of the effluent prior to discharge, especially with the use of chlorine, can create problems with both the soil and the drip disposal equipment.

If the effluent is disinfected prior to leaving the pump tank, all further biological activity is halted. This will eventually lead to the plugging of the soil with organic matter. Drip systems are commonly utilized on lots where no other disposal method can work. This will lead to the failure of the system because of the lingering, accumulation effect of the chlorine residual, now in the soil. An important part of the decomposition process of chlorine is exposure to sunlight. This cannot take place if the effluent is subsurface discharged.

The Bioline, pressure compensating drip tubing has a diaphragm that regulates the flow from the emitter. This diaphragm is made of EPDM Rubber. Over years of exposure to constantly chlorinated water, these diaphragms will break down, leading to the inability of the tubing to regulate the

pressure. There are no known studies that can provide information on the expected life of the emitters if exposed to chlorine. We are certain that this will lead to premature failure. The tubing has an anticipated life of 30 years when maintained, however there is no warranty on the tubing if chlorine is constantly utilized with the system.

In all cases, Chlorine should not be utilized except where require by law. At the current time, this would only be in installations where fractured rock is encountered less than 1 foot below the dripper line.

Chlorine can be used (10% solution) to clean the filter(s) on the system. Chlorine can be also be used to shock the pump tank, but do not field flush the system with this effluent. The high concentration of chlorine returning to the pre-treatment tank could severely disrupt the system and ruin the treatment process.

**IF ANY DRIP SYSTEM MUST UTILIZE CHLORINE FOR DISINFECTION, THEN THE FILED FLUSH/RETURN MANIFOLD LINES MUST RETURN TO THE PUMP TANK AND NOT THE PRETREATMENT TANK. THIS WILL CAUSE THE SYSTEM TO FAIL AND NEVER PROPERLY FUNCTION.**

If disinfection is required, it would be advantageous for the installer to utilize alternate methods of disinfection such as Ozone or UV. Both of these methods have no residual effects, and therefore will allow for biological activity to continue in the soil. The rate of decomposition will be slowed in comparison to non disinfected effluent, and again is not recommended unless required by law.

## HOOT Chlorination System

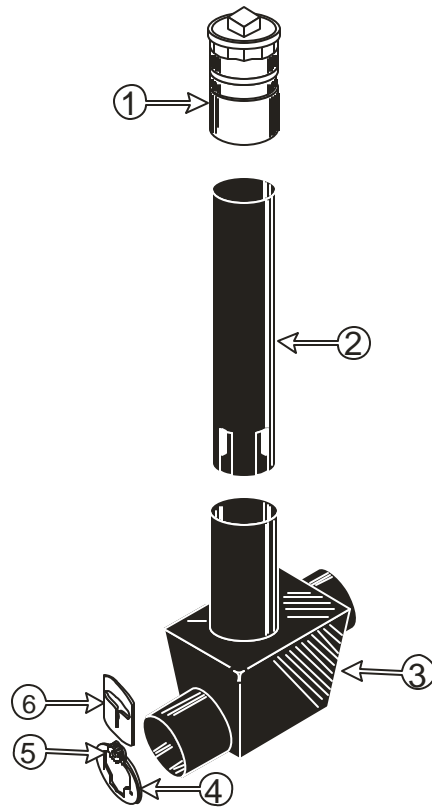

- |                               |                       |
|-------------------------------|-----------------------|
| 1. Chlorinator Cap            | 4. Weir Frame         |
| 2. Chlorine Tube              | 5. Flow Control Plate |
| 3. Chlorine Contact Reservoir | 6. Adjustment Knob    |

### Chlorination System

The HOOT Chlorine Delivery System is the finest in line, small flow chlorinator available on the market. The Chlorine Tube is larger than before, and this increase in diameter does not allow the tablets to expand out and get hung up in the tube. The tube has a ribbed bottom which keeps the tablets raised up so that water can pass under them for even dissolving. The Chlorine Contact Reservoir bottom allows for storage of chlorinated water and the when new water enters, it displaces the chlorinated water the reservoir was holding. This eliminates the problem associated with open bottom chlorinators which achieve insufficient contact with the tablets. The level of the water in the reservoir is pre-set to the middle setting, however it should be checked before you leave the installation. If upon inspection the system has been going through a large amount of chlorine, or the residual exceeds 1.0, then the level in the reservoir can be lowered by turning the Adjustment Knob counter clock wise. If it is at the lowest possible setting, and still too much chlorine is being used, then raise the tablets off of the bottom of the chlorine tube by the use of the 1 ½ spacer provided in the control box. If the Chlorine residual is below 0.1, then raise the level in the reservoir by turning the Adjustment Knob clock wise. To service or change the Chlorine level sensor, pull the Adjustment Knob forward and lift the Flow Control Plate from the Weir Frame, you will now be able to reach the sensor for replacement.

## **XII. System Components and Catalog**

Just as important as the proper design is the quality of components utilized for the project. As we have discussed earlier, Drip Irrigation has its roots in the agriculture industry. The water used by the agriculture industry, although often not tap water, is much less demanding than treated septic effluent.

We have evaluated, designed and tested the following components listed in this catalog and stand behind their application to the wastewater field. We strove to bring you these components at the best possible price, however these components are often more expensive than standard irrigation parts found at your local irrigation supply house or home improvement centers.

The Drip Disposal system is so integral to the success of the overall treatment and disposal process that Hoot Aerobic Systems must approve the components being incorporated into the system. Many states now require the Treatment System Manufacturers to certify that the treatment system and disposal system are made to work together.

Hoot cannot allow for the substitution of components integral to the disposal process. This would include the substitution of filtration equipment, tubing and controls. Each treatment plant must have a controller that is approved by the manufacturer as part of the certification from the testing agency. Hoot cannot sell its Drip irrigation series of controllers unless there is a purchase also made of tubing and one of the four different available filtration models.

If you find a product you feel is superior, in any way, to the components we have incorporated into our system, please let us know. We will be glad to evaluate it for use with our systems and will incorporate it if it proves to be better than or equal in both quality, durability and price.

The following pages contain cut sheets of the various components for the incorporation into designs and for regulatory evaluation. If you require additional information about any of the specific components, it may be obtained directly from the manufacturer.

## Controllers



# HOOT AEROBIC TREATMENT SYSTEM CONTROLLER



This product has been tested in accordance with the criteria as set forth in the ANSI/NSF Standard 40 and is hereby certified as conforming with requirements for classification as a CLASS 1 Wastewater Treatment Plant.

**SYSTEM CONTROL CENTER**



**SILENCE ALARM**

<input checked="" type="checkbox"/>	<b>SYSTEM OK</b>
<input type="checkbox"/>	<b>SYSTEM ALARM</b>
<input type="checkbox"/>	<b>WATER LEVEL PROBLEM</b>
<input type="checkbox"/>	<b>AERATION PROBLEM</b>
<input type="checkbox"/>	<b>ADD CHLORINE</b>

**DON'T POLLUTE, INSTALL A HOOT!**  
**Hoot Aerobic Systems, Inc.**  
**2885 Highway 14 East**  
**Lake Charles, LA 70607**  
**(337) 474-2804**

The Hoot System Controller has been designed to handle the demands of properly dosing a drip irrigation system. The Controller can operate the Manual, Manual Filter with Auto-Field Flush or the Automatic System utilizing the current 2000 Model System Controller. The controller requires the use of a Drip Probe (4 wire) to function properly.

### Manual & Semi Auto System Controller

The controller utilizes the same board as the standard Hoot System, with a different chip, to change how the system functions. See the Drip Loading Schedule on the following page to determine the settings required to make your system function properly.

### Automatic System Controller

The system is substantially based on the same technology as the Manual Filter Controller, with the same board and chip, however the controller is larger (an 8"x8" box as opposed to a 8"x6" box) because it contains an additional transformer and relays to drive solenoids.

This system is recommended for ALL Commercial installations where drip is utilized. The Automated systems will not only perform a field flush once per week, but will also, with the Automatic Filter, Back flush the filter every fourth dose.

This will minimize the installer input required to keep the system functioning properly.

# Manual Filtration System

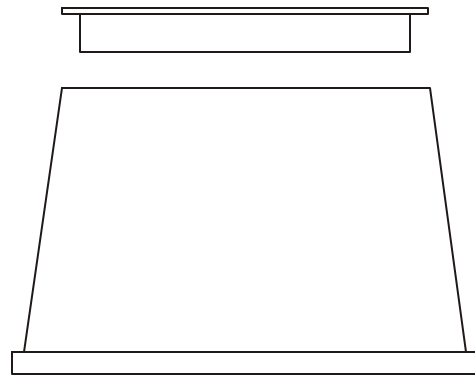
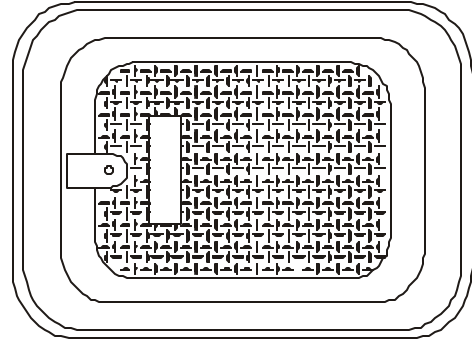
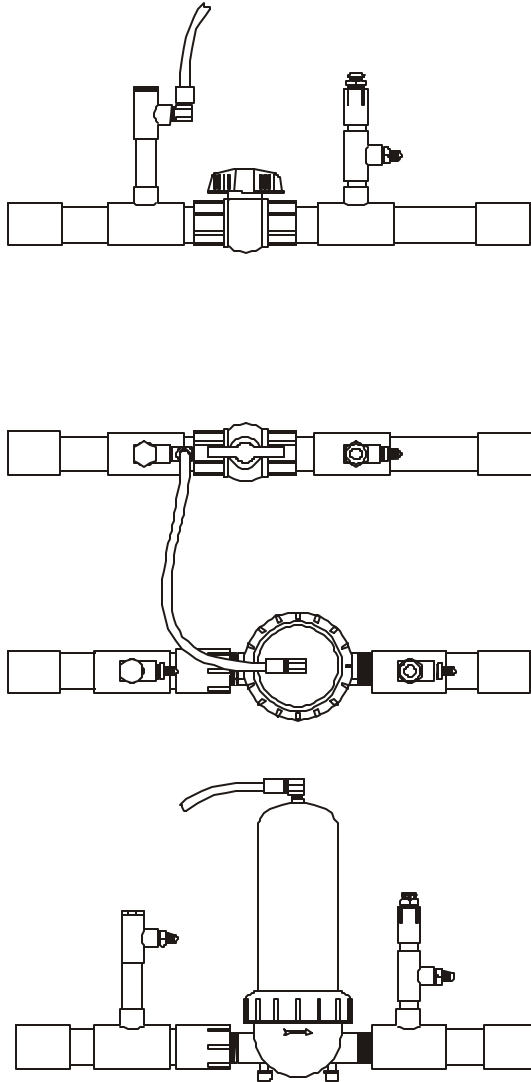

The Hoot Manual Filtration system features all of the components necessary for single zone drip systems.

The location of the drip box must be at the highest point on the drip field. If it cannot be located at the highest point on the system, then it will be necessary to re-locate the air release valves to the highest point. Simply remove the air release valves from the 1/2" female adapters and replace them with 1/2" threaded plugs.

The air release valves can be re-located to the highest points on the manifold underneath a round irrigation valve box.

If multiple zones are needed to complete the system, the same procedure as above must be followed for each zone. Also be certain that a check valve is located on each return manifold so that the system will not pressurize additional zones.

# Manual Filtration System w/ Auto Field Flush

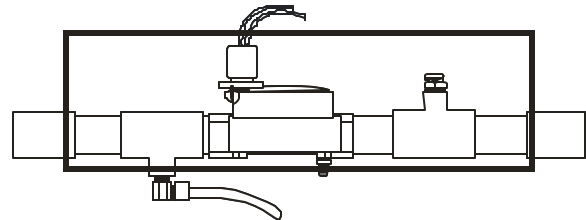
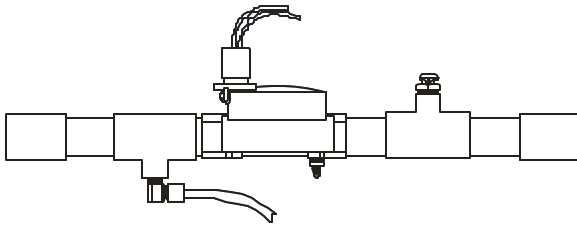
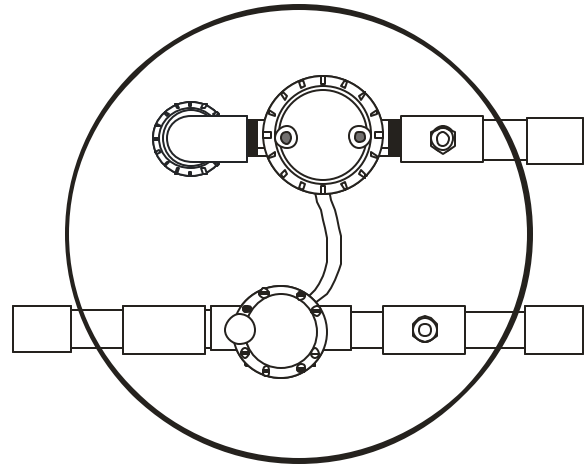
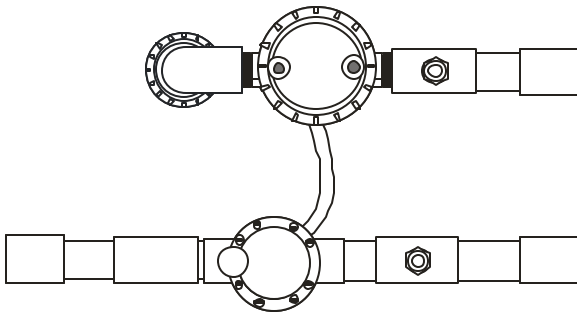
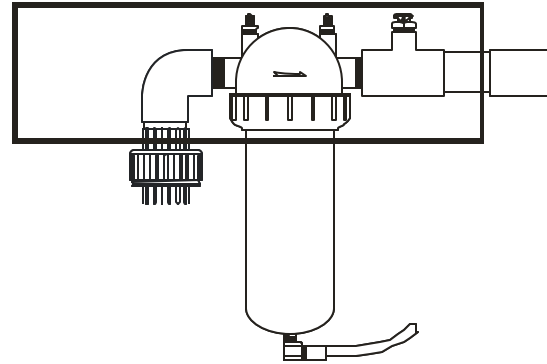
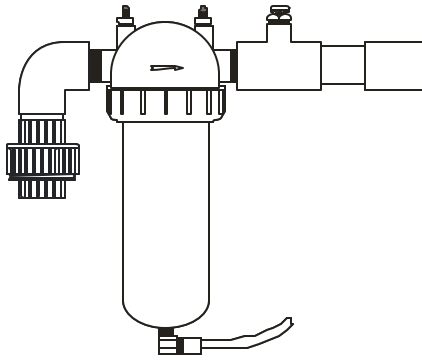

This filter system is a step up from the Manual Filtration System and is designed to keep the system running properly with reduced installer or service provider input.

Once every week a field flushing day occurs. On the field flush day, the lines are flushed 4 times, which allows for a minimum of once per zone on multi zone systems.

The Semi-Automatic Filter is recommended over the Manual Filter System or Kit for all systems installed in the following conditions.

Where slopes of greater than 10 Degrees are encountered

Tight clay soils

Systems which have high occupancy or use (High levels of grease, etc.)

Service visits with this system will only require manually cleaning the filter. It is recommended to force the system into a field flush to ensure the system is functioning properly.

This system is not recommended for Commercial use, please refer to the Automatic System on the following page.

## Components

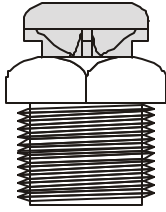

### **Air Release Valve**

Standard 1/2" Air Release Valve to be used on each zone, at highest point of both the supply and return manifolds. Proper air release prevents the "Fines" from being drawn into tubing.

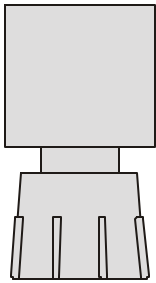

### **Spin Lock Connector - Slip**

Standard 1/2" slip glue connection to 1/2" tubing connection. Features an O-Ring and compression seal and can be reused. Allows for simple hook up with no special tools required.

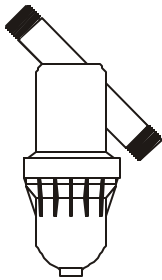

### **Arkal 3/4" Disc Filter**

In line 3/4" ring disc filter provides 3-Dimensional filtration of effluent. Particles cannot be "squeezed" through filter like the competition. Simple cartridge removal for cleaning. Includes 1/4" tap for constant flush.

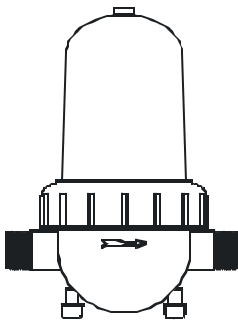

### **Arkal 1" and 1" Super Disc Filter**

Features include all from 3/4" Filter. Different is 1" mpt connections. Pressure check points allow for clogged filter diagnosis with a needle valve gauge. 1" Super doubles the surface area for filtration.

## Components

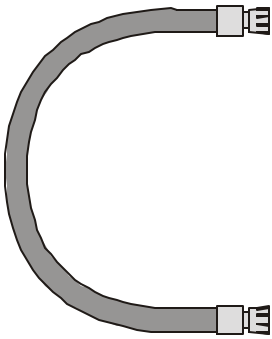

### **Flex Loop**

Features 40" of 1/2" Flexible schedule 40 PVC with spin lock connectors on each end. Perfect length to loop tubing on 24" centers. Flexible PVC bends in shrink swell soils instead of tubing kinking.

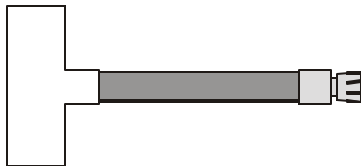

### **Flex Connect**

Provides 1 1/4" Schedule 40 T to 1/2" w/ 12" of 1/2" flex PVC with spin lock connector. Allows for movement in shrink swell soils without kinking. For both supply and return manifold connections.

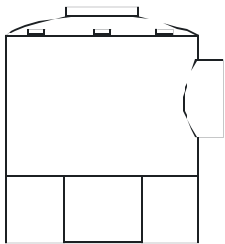

### **Hydrotek Zone Valve**

Multi-position zone valve allows for simple and equal duration zone control configurations. Each time pump comes on the valve advances to the next field. Available in 2 thru 4 zone configurations.

(specify 2, 3, or 4)

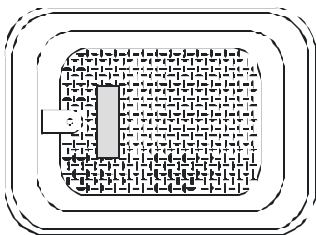

### **Valve Box**

Available in small 13" x 16" in 6"(S) or 14"(T) depth or large 16" x 24" X 14". Included with Manual or Automatic Filter Boxes. Can be purchased separately for water meters, solenoid or zone valves.

# 500 GPD DRIP SYSTEM H-500 AND,CP

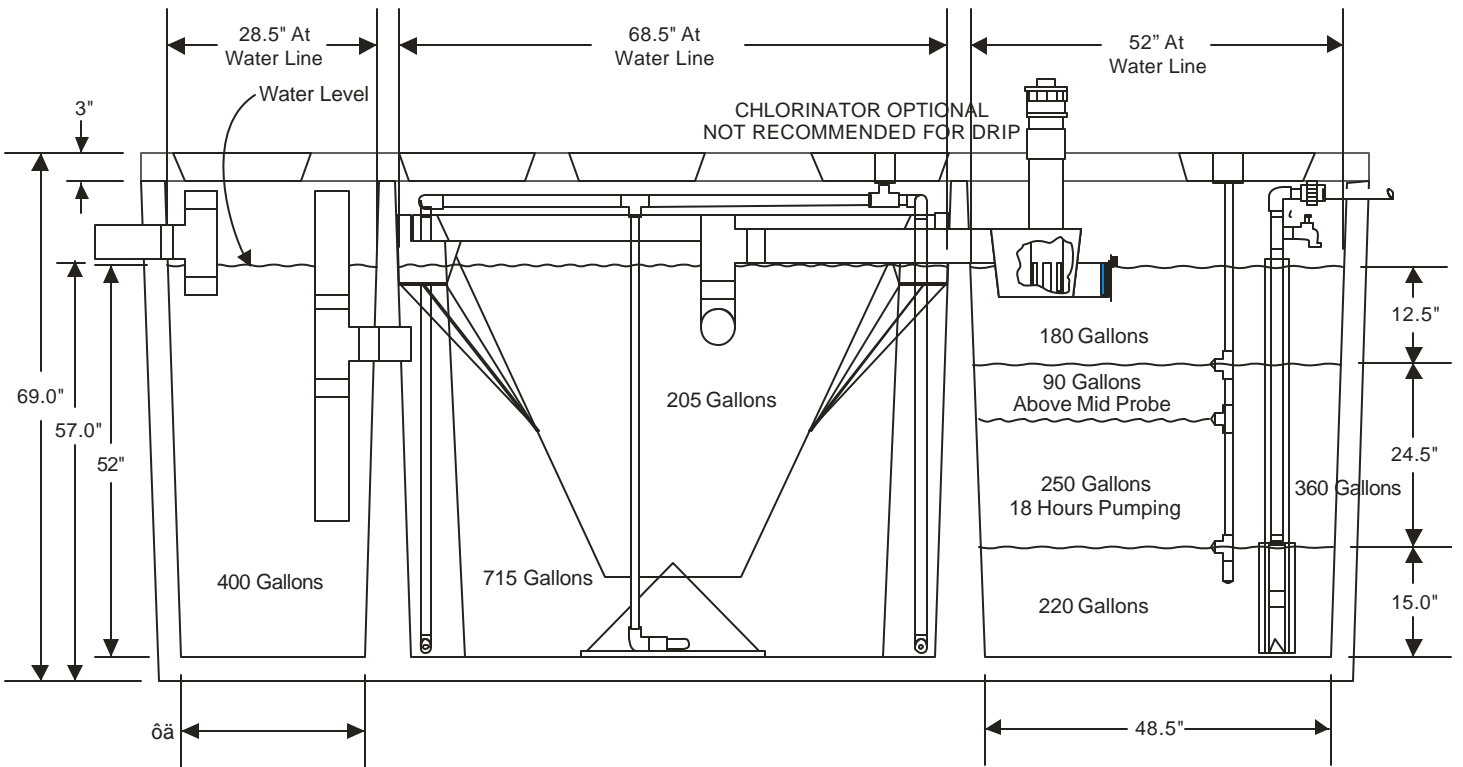
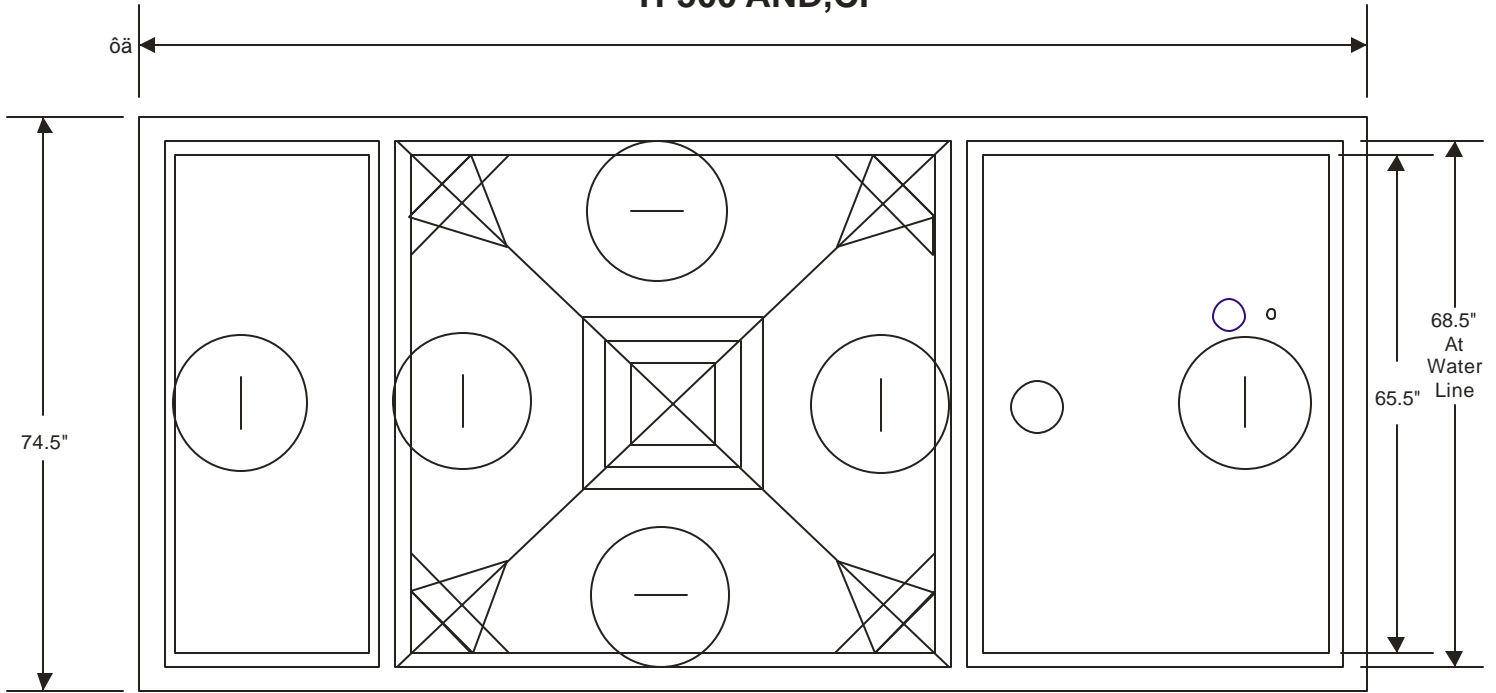

2.229' Avg. Length  
5.600' Avg. Width  
4.333' Depth

4.187' Avg. Length  
5.600' Avg. Width  
4.333' Depth

760 Gallons  
220 Gallons Remaining In Tank

540 Gallons Holding Capacity

# 750 GPD DRIP SYSTEM H-750 AND,CP

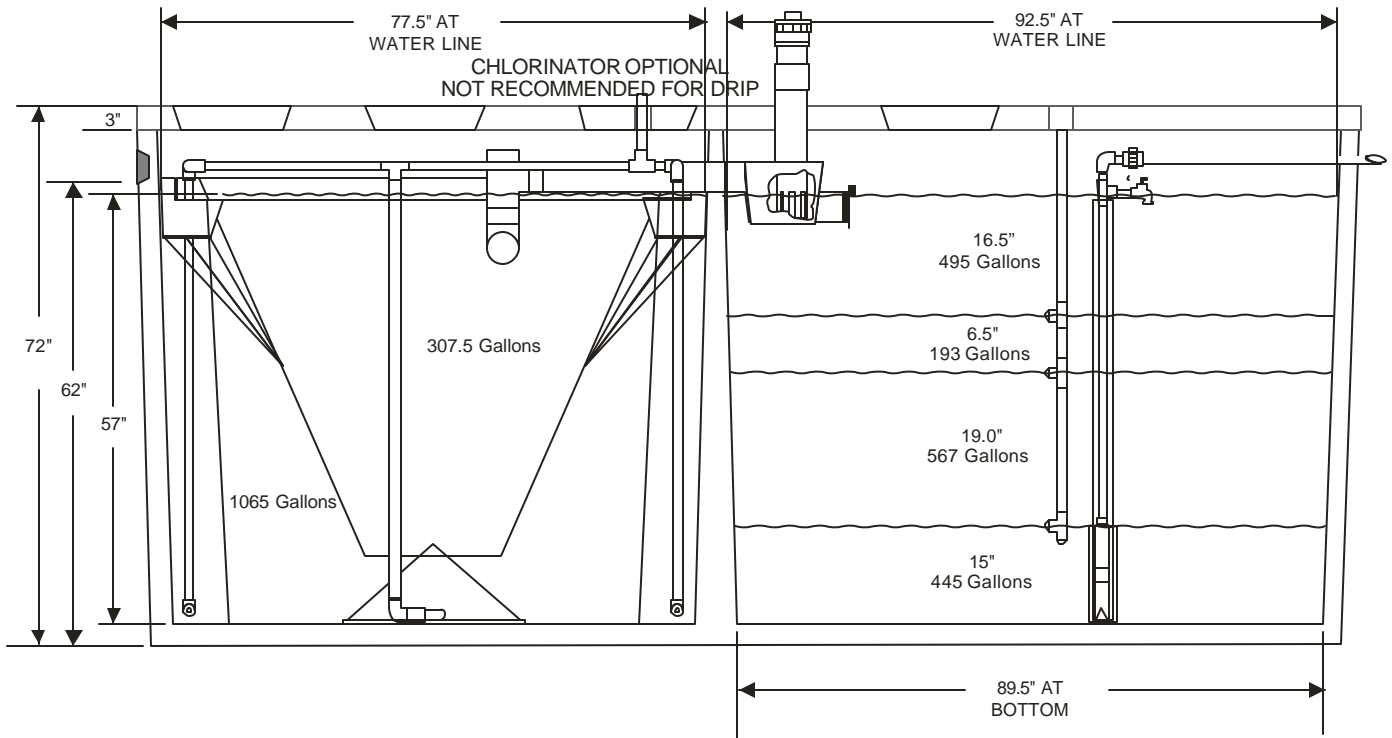
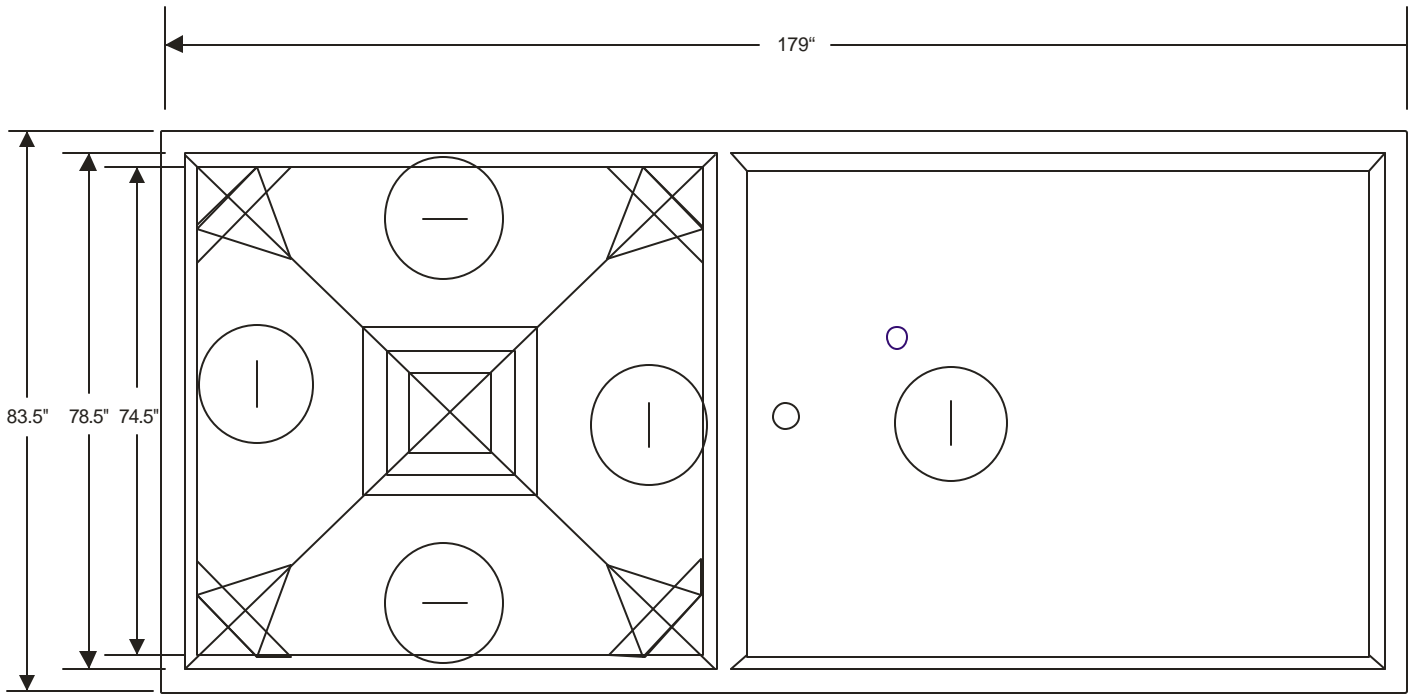

76" Avg. Length  
76" Avg. Width  
57" Depth

91" Avg. Length  
76" Avg. Width  
57" Depth

1700 Gallons  
445 Gallons Remaining In Tank

1255 Gallons Pumping Capacity

# 1000 GPD DRIP SYSTEM H-1000 AND, CP

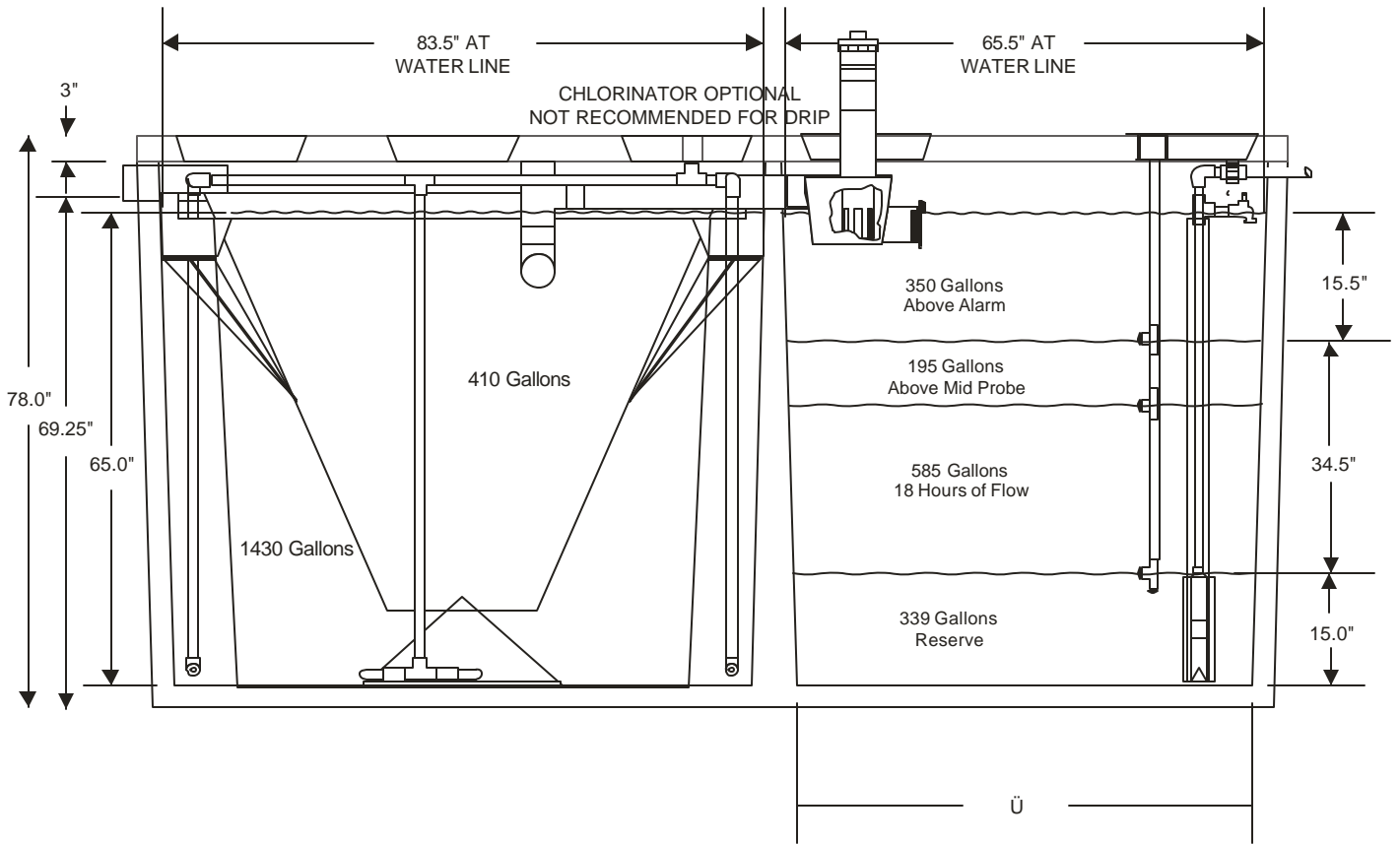
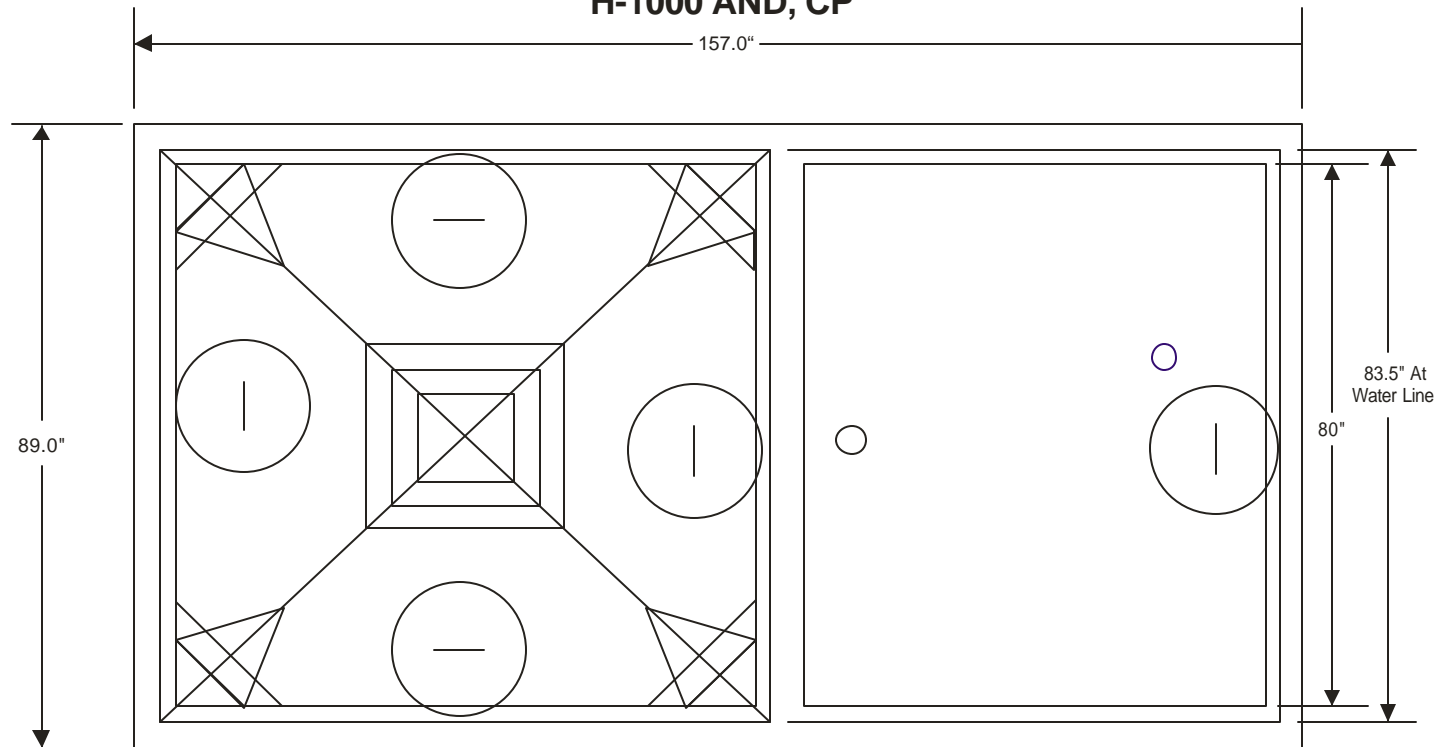

5.312' Avg. Length  
6.812' Avg. Width  
5.416' Depth

1469 Gallons  
339 Gallons Remaining In Tank  
1130 Gallons Pumping Capacity